

# Air-Conditioners

## SLZ-A09, A12, A18AR

### INSTALLATION MANUAL

For safe and correct use, please read this installation manual thoroughly before installing the air-conditioner unit.

FOR INSTALLER

### INSTALLATIONSHANDBUCH

Zum sicheren und ordnungsgemäßen Gebrauch der Klimaanlage das Installationshandbuch gründlich durchlesen.

FÜR INSTALLATEURE

### MANUEL D'INSTALLATION

Veuillez lire le manuel d'installation en entier avant d'installer ce climatiseur pour éviter tout accident et vous assurer d'une utilisation correcte.

POUR L'INSTALLATEUR

### INSTALLATIEHANDLEIDING

Voor een veilig en juist gebruik moet u deze installatiehandleiding grondig doorlezen voordat u de airconditioner installeert.

VOOR DE INSTALLATEUR

### MANUAL DE INSTALACIÓN

Para un uso seguro y correcto, lea detalladamente este manual de instalación antes de montar la unidad de aire acondicionado.

PARA EL INSTALADOR

### MANUALE DI INSTALLAZIONE

Per un uso sicuro e corretto, leggere attentamente questo manuale di installazione prima di installare il condizionatore d'aria.

PER L'INSTALLATORE

### ΕΓΧΕΙΡΙΔΙΟ ΟΔΗΓΙΩΝ ΕΓΚΑΤΑΣΤΑΣΗΣ

Για ασφάλεια και σωστή χρήση, παρακαλείστε διαβάσετε προσεκτικά αυτό το εγχειρίδιο εγκατάστασης πριν αρχίσετε την εγκατάσταση της μονάδας κλιματισμού.

ΓΙΑ ΑΥΤΟΝ ΠΟΥ ΚΑΝΕΙ ΤΗΝ ΕΓΚΑΤΑΣΤΑΣΗ

### MANUAL DE INSTALAÇÃO

Para segurança e utilização correctas, leia atentamente este manual de instalação antes de instalar a unidade de ar condicionado.

PARA O INSTALADOR

### INSTALLATIONSMANUAL

Läs denna installationsmanual noga för säkert och korrekt bruk innan luftkonditioneringen installeras.

FÖR INSTALLATÖREN

English

Deutsch

Français

Nederlands

Español

Italiano

Ελληνικά

Português

Svenska

# Contents

1. Safety precautions .....	2	9. Installing the remote controller .....	12
2. Selecting the installation location .....	2	10. Test run .....	12
3. Installation diagram .....	3	11. Maintenance .....	13
4. Installing the indoor unit .....	3		
5. Refrigerant piping work .....	5		
6. Drainage piping work .....	7		
7. Electrical work .....	8		
8. Installing the grille .....	9		

This Installation Manual describes only for the indoor unit and the connected outdoor unit of SUZ series.  
If the connected outdoor unit is MXZ series, refer to the Installation Manual for MXZ series.

## 1. Safety precautions

- **Be sure to read “The following should always be observed for safety” before installing the air conditioner.**
  - **Be sure to observe the cautions specified here as they include important items related to safety.**
  - **The indications and meanings are as follows.**
- ⚠ Warning:**  
Could lead to death, serious injury, etc.
- ⚠ Caution:**  
Could lead to serious injury in particular environments when operated incorrectly.
- **After reading this manual, be sure to keep it together with the instruction manual in a handy place on the customer’s site.**

- ⊘ : Indicates an action that must be avoided.
  - ❗ : Indicates that important instructions must be followed.
  - ⚡ : Indicates a part which must be grounded.
  - ⚠ : Indicates that caution should be taken with rotating parts.
  - ⚠ : Indicates that the main switch must be turned off before servicing.
  - ⚠ : Beware of electric shock.
  - ⚠ : Beware of hot surface.
- ⚠ Warning:**  
Carefully read the labels affixed to the main unit.

- ⚠ Warning:**
- **Do not install it by yourself (customer).**  
Incomplete installation could cause injury due to fire, electric shock, the unit falling or leakage of water. Consult the dealer from whom you purchased the unit or special installer.
  - **Install the unit securely in a place which can bear the weight of the unit.**  
When installed in an insufficient strong place, the unit could fall causing injured.
  - **Use the specified wires to connect the indoor and outdoor units securely and attach the wires firmly to the terminal board connecting sections so the stress of the wires is not applied to the sections.**  
Incomplete connecting and fixing could cause fire.
  - **Do not use intermediate connection of the power cord or the extension cord and do not connect many devices to one AC outlet.**  
It could cause a fire or an electric shock due to defective contact, defective insulation, exceeding the permissible current, etc.
  - **Check that the refrigerant gas does not leak after installation has completed.**

- **Perform the installation securely referring to the installation manual.**  
Incomplete installation could cause a personal injury due to fire, electric shock, the unit falling or leakage of water.
- **Perform electrical work according to the installation manual and be sure to use an exclusive circuit.**  
If the capacity of the power circuit is insufficient or there is incomplete electrical work, it could result in a fire or an electric shock.
- **Attach the electrical part cover to the indoor unit and the service panel to the outdoor unit securely.**  
If the electrical part cover in the indoor unit and/or the service panel in the outdoor unit are not attached securely, it could result in a fire or an electric shock due to dust, water, etc.
- **Be sure to use the part provided or specified parts for the installation work.**  
The use of defective parts could cause an injury or leakage of water due to a fire, an electric shock, the unit falling, etc.
- **Ventilate the room if refrigerant leaks during operation.**  
If the refrigerant comes in contact with a flame, poisonous gases will be released.

- ⚠ Caution:**
- **Perform grounding.**  
Do not connect the ground wire to a gas pipe, water pipe arrester or telephone ground wire. Defective grounding could cause an electric shock.
  - **Do not install the unit in a place where an inflammable gas leaks.**  
If gas leaks and accumulates in the area surrounding the unit, it could cause an explosion.
  - **Install a ground leakage breaker depending on the installation place (where it is humid).**  
If a ground leakage breaker is not installed, it could cause an electric shock.

- **Perform the drainage/piping work securely according to the installation manual.**  
If there is a defect in the drainage/piping work, water could drop from the unit and household goods could be wet and damaged.
- **Fasten a flare nut with a torque wrench as specified in this manual.**  
When fastened too tight, a flare nut may broken after a long period and cause a leakage of refrigerant.

## 2. Selecting the installation location

### 2.1. Indoor unit

- Where airflow is not blocked.
- Where cool air spreads over the entire room.
- Where it is not exposed to direct sunshine.
- At a distance 1 m or more away from your TV and radio (to prevent picture from being distorted or noise from being generated).
- In a place as far away as possible from fluorescent and incandescent lights (so the infrared remote control can operate the air conditioner normally).

- Where the air filter can be removed and replaced easily.

**⚠ Warning:**  
Mount the indoor unit into a ceiling strong enough to withstand the weight of the unit.

### 2.2. Outdoor unit

- Where it is not exposed to strong wind.
- Where airflow is good and dustless.
- Where it is not exposed to rain and direct sunshine.
- Where neighbours are not annoyed by operation sound or hot air.
- Where rigid wall or support is available to prevent the increase of operation sound or vibration.
- Where there is no risk of combustible gas leakage.
- When installing the unit at a high level, be sure to fix the unit legs.
- Where it is at least 3 m away from the antenna of TV set or radio. (Otherwise, images would be disturbed or noise would be generated.)

- Install the unit horizontally.

**⚠ Caution:**  
Avoid the following places for installation where air conditioner trouble is liable to occur.

- **Where there is too much machine oil.**
- **Salty environment as seaside areas.**
- **Hot-spring areas.**
- **Where sulfide gas exists.**
- **Other special atmospheric areas.**

## 2. Selecting the installation location

### 2.3. Wireless remote controller mounting

- Place of mounting
  - Where it is easy to operate and easily visible.
  - Where children can not touch.
- Mounting

Select a position about 1.2 m above the floor, check that signals from the remote controller are surely received by the indoor unit from that position ('beep' or 'beep-beep' receiving tone sounds). After that, attach remote controller holder to a pillar or wall and set the wireless remote controller.

In rooms where inverter type fluorescent lamps are used, the signal from the wireless remote controller may not be received.

## 3. Installation diagram

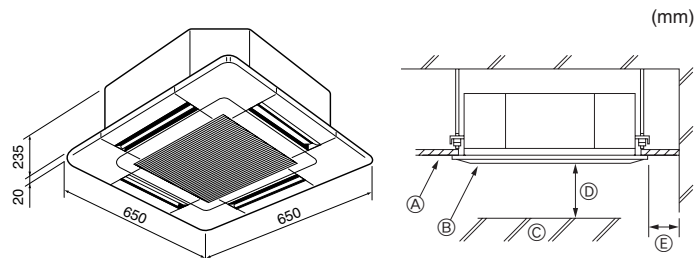
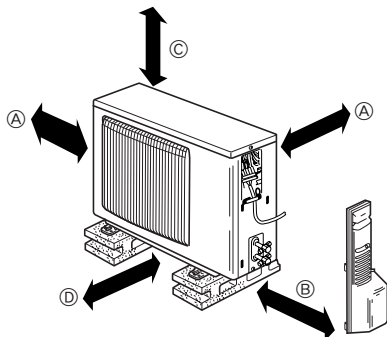

Fig. 3-1

#### ■ SUZ-A09/A12



#### ■ SUZ-A18

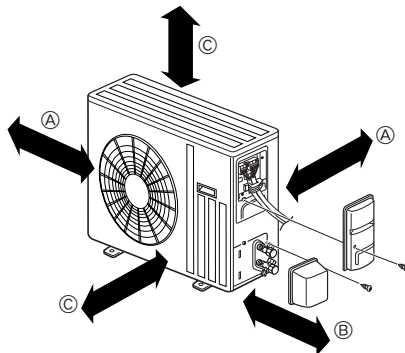

Fig. 3-2

### 3.1. Indoor unit (Fig. 3-1)

- Ⓐ Ceiling
- Ⓑ Grille
- Ⓒ Obstacle
- Ⓓ Min. 1000 mm
- Ⓔ Min. 500 mm (Entire periphery)

If setting the maintenance space for Ⓔ, be sure to leave a minimum of 700 mm.

### 3.2. Outdoor unit (Fig. 3-2)

#### Ventilation and service space

##### ■ SUZ-A09/A12

- Ⓐ 100 mm or more
- Ⓑ 350 mm or more
- Ⓒ Basically open 100 mm or more without any obstruction in front and on both sides of the unit.
- Ⓓ 200 mm or more (Open two sides of left, right, or rear side.)

##### ■ SUZ-A18

- Ⓐ 100 mm or more
- Ⓑ 350 mm or more
- Ⓒ 500 mm or more

When the piping is to be attached to a wall containing metals (tin plated) or metal netting, use a chemically treated wooden piece 20 mm or thicker between the wall and the piping or wrap 7 to 8 turns of insulation vinyl tape around the piping.

Units should be installed by licensed contractor accordingly to local code requirement.

## 4. Installing the indoor unit

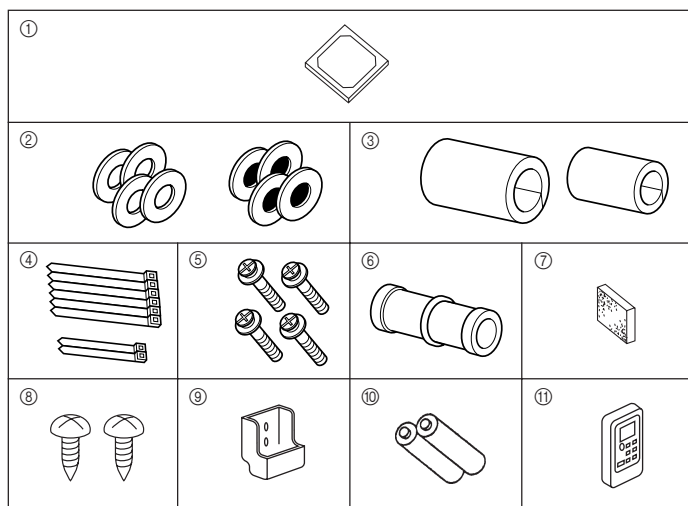

Fig. 4-1

### 4.1. Check the indoor unit accessories (Fig. 4-1)

The indoor unit should be supplied with the following accessories.

	Accessory name	Q'ty
①	Installation template	1
②	Washers (with insulation)	4
	Washers (without insulation)	4
③	Pipe cover (for refrigerant piping joint)	
	small diameter (liquid)	1
	large diameter (gas)	1
④	Band (large)	6
	Band (small)	2
⑤	Screw with washer (M5 × 25) for mounting grille	4
⑥	Drain socket	1
⑦	Insulation	1
⑧	Fixing screw for ⑨ 3.5 × 1.6 (Black)	2
⑨	Remote controller holder	1
⑩	Battery (AAA)	2
⑪	Wireless remote controller	1

## 4. Installing the indoor unit

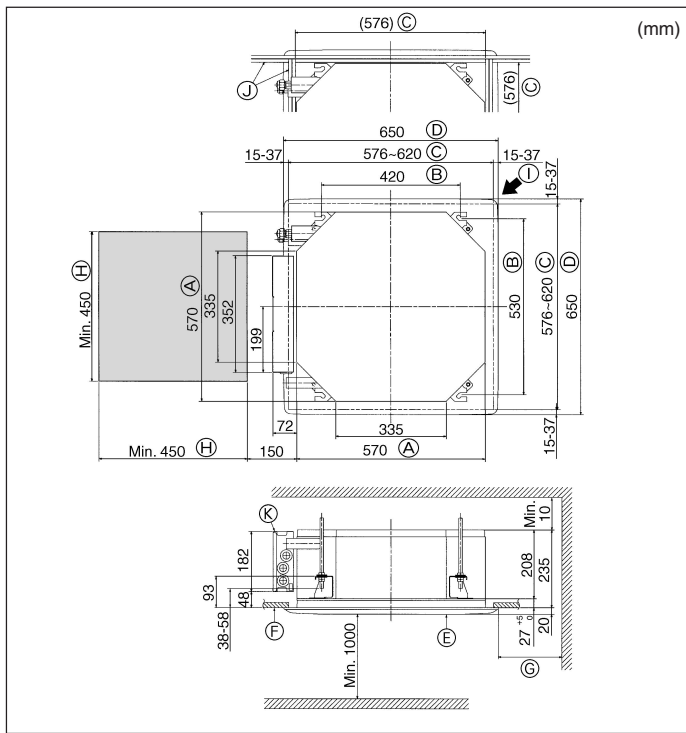

Fig. 4-2

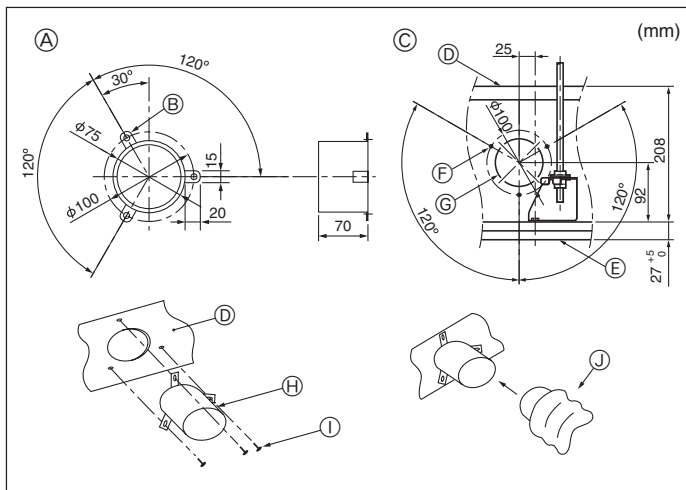

Fig. 4-3

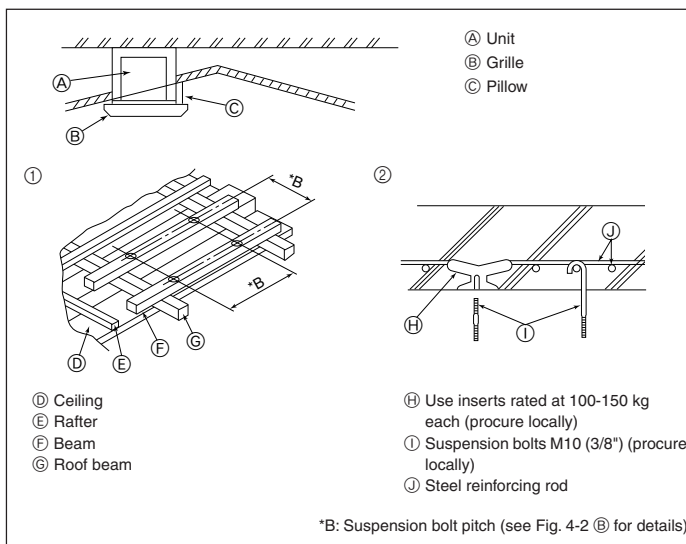

Fig. 4-4

## 4.2. Ceiling openings and suspension bolt installation locations (Fig. 4-2)

- Using the installation template (top of the package) and the gauge (supplied as an accessory with the grille), make an opening in the ceiling so that the main unit can be installed as shown in the diagram. (The method for using the template and the gauge are shown.)
    - Before using, check the dimensions of template and gauge, because they change due to fluctuations of temperature and humidity.
    - The dimensions of ceiling opening can be regulated within the range shown in following diagram; so center the main unit against the opening of ceiling, ensuring that the respective opposite sides on all sides of the clearance between them becomes identical.
  - Use M10 (3/8") suspension bolts.
    - Suspension bolts are to be procured at the field.
  - Install securely, ensuring that there is no clearance between the ceiling panel & grille, and between the main unit & grille.
    - (A) Outer side of main unit
    - (B) Bolt pitch
    - (C) Ceiling opening
    - (D) Outer side of Grille
    - (E) Grille
    - (F) Ceiling
    - (G) Min. 500 mm (Entire periphery) If setting the maintenance space for (H), be sure to leave a minimum of 700 mm.
    - (H) Maintenance space
    - (I) Fresh air intake
    - (J) Angle
    - (K) Electric component box
- \* Note that the space between ceiling panel of the unit and ceiling slab and etc must be 10 to 15 mm to be left.  
 \* Leave the maintenance space at the electric component box end.

## 4.3. Installation of duct (in case of fresh air intake) (Fig. 4-3)

### ⚠ Caution:

#### Linkage of duct fan and air conditioner

In case that a duct fan is used, be sure to make it linked with the air conditioner when outside air is taken.

Do not run the duct fan only. It can cause dew drop.

#### Making a duct flange (prepared locally)

- The shape of duct flange shown left is recommended.

#### Installation of duct flange

- Cut out the cutout hole. Do not knock it out.
- Install a duct flange to the cutout hole of the indoor unit with three 4 × 10 tapping screws which should be prepared locally.

#### Installation of duct (should be prepared locally)

- Prepare a duct of which inner diameter fits into the outer diameter of the duct flange.
- In case that the environment above the ceiling is high temperature and high humidity, wrap the duct in a heat insulate to avoid causing dew drop on the wall.

- (A) Duct flange recommended shape (Thickness: 0.8 or more)
- (B) 3-φ5 hole
- (C) Detail drawing of fresh air intake
- (D) Indoor unit
- (E) Ceiling surface
- (F) 3-φ2.8 Burring hole
- (G) φ73.4 cutout hole
- (H) Duct flange (Prepared locally)
- (I) 4 × 10 Tapping screw (Prepared locally)
- (J) Duct

## 4.4. Suspension structure (Give site of suspension strong structure) (Fig. 4-4)

- The ceiling work differs according to the construction of the building. Building constructors and interior decorators should be consulted for details.
  - Extent of ceiling removal: The ceiling must be kept completely horizontal and the ceiling foundation (framework: wooden slats and slat holders) must be reinforced in order to protect the ceiling from vibration.
  - Cut and remove the ceiling foundation.
  - Reinforce the ends of the ceiling foundation where it has been cut and add ceiling foundation for securing the ends of the ceiling board.
  - When installing the unit on a slanting ceiling, interlock a pillow between the ceiling and the grille and set so that the unit is installed horizontally.
- ① Wooden structures
  - Use tie beams (single storied houses) or second floor beams (two story houses) as reinforcing members.
  - Wooden beams for suspending air conditioners must be sturdy and their sides must be at least 6 cm long if the beams are separated by not more than 90 cm and their sides must be at least 9 cm long if the beams are separated by as much as 180 cm. The size of the suspension bolts should be φ10 (3/8"). (The bolts do not come with the unit.)
- ② Ferro-concrete structures
  - Secure the suspension bolts using the method shown, or use steel or wooden hangers, etc. to install the suspension bolts.

## 4. Installing the indoor unit

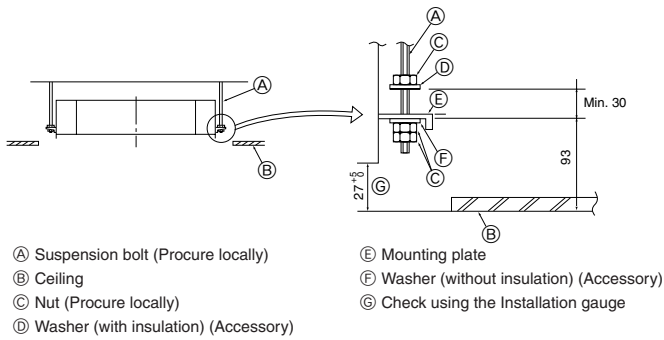

Fig. 4-5

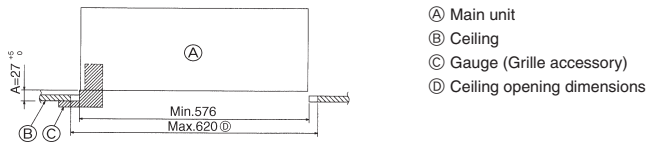

Fig. 4-6

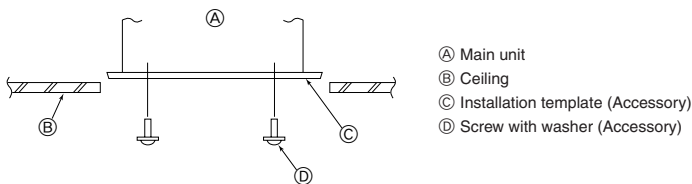

Fig. 4-7

## 5. Refrigerant piping work

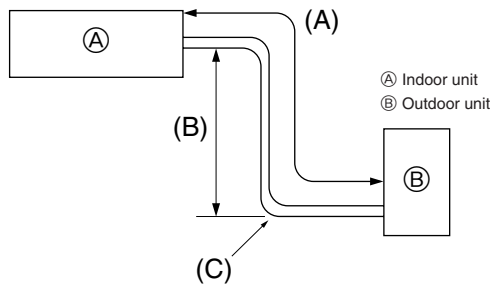

Fig. 5-1

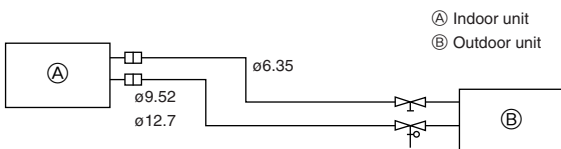

Fig. 5-2

### 4.5. Unit suspension procedures (Fig. 4-5)

Suspend the main unit as shown in the diagram.

- In advance, set the parts onto the suspension bolts in the order of the washers (with insulation), washers (without insulation) and nuts (double).
  - Fit the washer with cushion so that the insulation faces downward.
  - In case of using upper washers to suspend the main unit, the lower washers (with insulation) and nuts (double) are to be set later.
- Lift the unit to the proper height of the suspension bolts to insert the mounting plate between washers and then fasten it securely.
- When the main unit can not be aligned against the mounting hole on the ceiling, it is adjustable owing to a slot provided on the mounting plate. (Fig. 4-6)
  - Make sure that step A is performed within 27-32 mm. Damage could result by failing to adhere to this range.

### 4.6. Confirming the position of main unit and tightening the suspension bolts (Fig. 4-7)

- Using the gauge attached to the grille, ensure that the bottom of the main unit is properly aligned with the opening of the ceiling. Be sure to confirm this, otherwise condensation may form and drip due to air leakage etc.
- Confirm that the main unit is horizontally levelled, using a level or a vinyl tube filled with water.
- After checking the position of the main unit, tighten the nuts of the suspension bolts securely to fasten the main unit.
- The installation template can be used as a protective sheet to prevent dust from entering the main unit when the grilles are left unattached for a while or when the ceiling materials are to be lined after installation of the unit is finished.
- \* As for the details of fitting, refer to the instructions given on the Installation template.

### 5.1. Refrigerant pipe (Fig. 5-1)

► Check that the difference between the heights of the indoor and outdoor units, the length of refrigerant pipe, and the number of bends in the pipe are within the limits shown below.

Models	(A) Pipe length (one way)	(B) Height difference	(C) Number of bends (one way)
SLZ-A09/A12	max. 20 m	max. 12 m	max. of 10
SLZ-A18	max. 30 m	max. 15 m	max. of 10

- Height difference limitations are binding regardless of which unit, indoor or outdoor, is positioned higher.
- Refrigerant adjustment ... If pipe length exceeds 7 m, additional refrigerant (R410A) charge is required. (The outdoor unit is charged with refrigerant for pipe length up to 7 m.)

Pipe length	Up to 7 m	No additional charge is required.
	Exceeding 7 m	Additional charge is required. (Refer to the table below.)
Refrigerant to be added	SLZ-A09/A12 type	30 g × (refrigerant piping length (m) - 7)
	SLZ-A18 type	50 g × (refrigerant piping length (m) - 7)

#### Piping preparation

- Refrigerant pipes of 3, 5, 7, 10 and 15 m are available as optional items.

(1) Table below shows the specifications of pipes commercially available.

Model	Pipe	Outside diameter		Min wall thickness	Insulation thickness	Insulation material
		mm	inch			
SLZ-A09	For liquid	6.35	1/4	0.8 mm	8 mm	Heat resisting foam plastic 0.045 specific gravity
	For gas	9.52	3/8	0.8 mm	8 mm	
SLZ-A12	For liquid	6.35	1/4	0.8 mm	8 mm	
	For gas	9.52	3/8	0.8 mm	8 mm	
SLZ-A18	For liquid	6.35	1/4	0.8 mm	8 mm	
	For gas	12.7	1/2	0.8 mm	8 mm	

- Ensure that the 2 refrigerant pipes are well insulated to prevent condensation.
- Refrigerant pipe bending radius must be 100 mm or more.

#### ⚠ Caution:

Using careful insulation of specified thickness. Excessive thickness prevents storage behind the indoor unit and smaller thickness causes dew drippage.

## 5. Refrigerant piping work

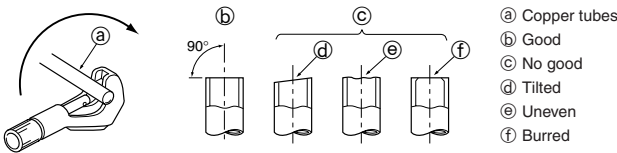

Fig. 5-3

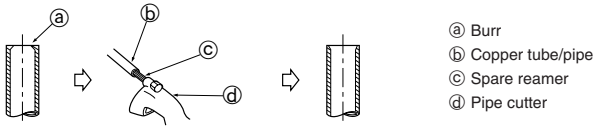

Fig. 5-4

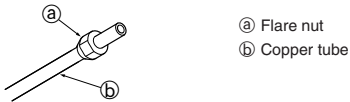

Fig. 5-5

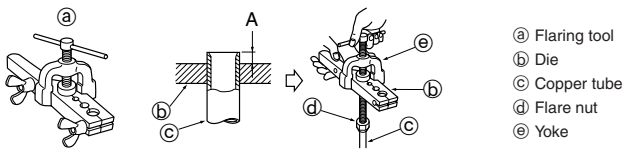

Fig. 5-6

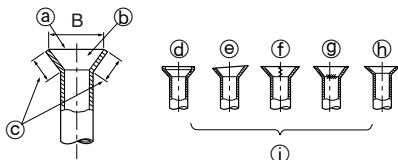

Fig. 5-7

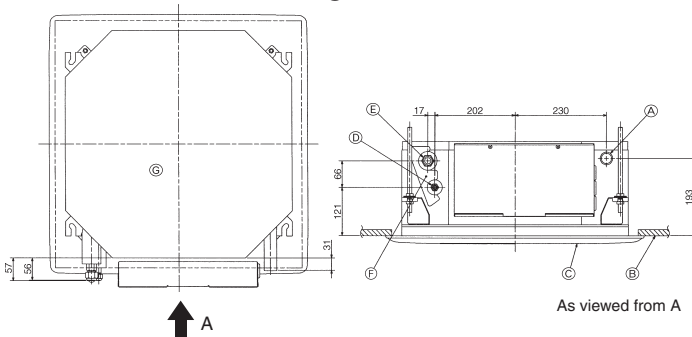

Fig. 5-8

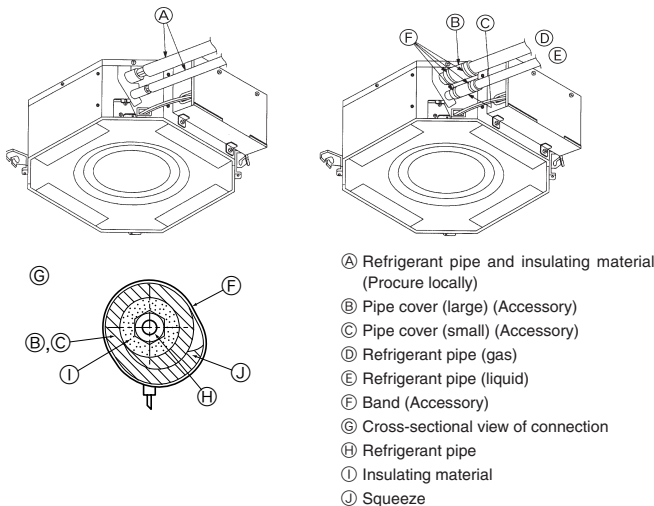

Fig. 5-9

### 5.2. Flaring work

- Main cause of gas leakage is defect in flaring work. Carry out correct flaring work in the following procedure.

#### 5.2.1. Pipe cutting (Fig. 5-3)

- Using a pipe cutter cut the copper tube correctly.

#### 5.2.2. Burrs removal (Fig. 5-4)

- Completely remove all burrs from the cut cross section of pipe/tube.
- Put the end of the copper tube/pipe to downward direction as you remove burrs in order to avoid burrs drop in the tubing.

#### 5.2.3. Putting nut on (Fig. 5-5)

- Remove flare nuts attached to indoor and outdoor unit, then put them on pipe/tube having completed burr removal. (not possible to put them on after flaring work)

#### 5.2.4. Flaring work (Fig. 5-6)

- Carry out flaring work using flaring tool as shown at the right.

Pipe diameter (mm)	Dimension	
	A (mm)	B $\pm 0.4$ (mm)
	When the tool for R410A is used	
6.35	0 - 0.5	9.1
9.52	0 - 0.5	13.2
12.7	0 - 0.5	16.6

Firmly hold copper tube in a die in the dimension shown in the table at above.

#### 5.2.5. Check (Fig. 5-7)

- Compare the flared work with a figure in rightside hand.
- If flare is noted to be defective, cut off the flared section and do flaring work again.

- (a) Smooth all around
- (b) Inside is shining without any scratches
- (c) Even length all around
- (d) Too much
- (e) Tilted
- (f) Scratch on flared plane
- (g) Cracked
- (h) Uneven
- (i) Bad examples

### 5.3. Refrigerant and drainage piping locations (Fig.5-8)

- (A) Drain pipe
- (B) Ceiling
- (C) Grille
- (D) Refrigerant pipe (liquid)
- (E) Refrigerant pipe (gas)
- (F) Water supply inlet
- (G) Main unit

### 5.4. Pipe connection (Fig. 5-9)

#### Indoor unit

##### 1) When using commercially available copper pipes:

- Apply thin layer of refrigerant oil to pipe and joint seating surface before tightening flare nut.
- Use two wrenches to tighten piping connections.
- Air-purge the refrigerant piping using your own refrigerant gas (don't air-purge the refrigerant charged in the outdoor unit).
- Use leak detector or soapy water to check for gas leaks after connections are completed.
- Use refrigerant piping insulation provided to insulate indoor unit connections. Insulate carefully following shown below.

##### 2) Heat insulation for refrigerant pipes:

- Wrap the enclosed large-sized pipe cover around the gas pipe, making sure that the end of the pipe cover touches the side of the unit.
- Wrap the enclosed small-sized pipe cover around the liquid pipe, making sure that the end of the pipe cover touches the side of the unit.
- Secure both ends of each pipe cover with the enclosed bands. (Attach the bands 20 mm from the ends of the pipe cover.)

See that stop valve on outdoor unit is fully shut (unit is shipped with valve shut). After all piping connections between indoor and outdoor unit have been completed, vacuum-purge air from system through the service port for the stop valve on the outdoor unit.

After completing procedures above, open outdoor unit stop valves stem fully. This completes connection of refrigerant circuit between indoor and outdoor units. Stop valve instructions are marked on outdoor unit.

## 5. Refrigerant piping work

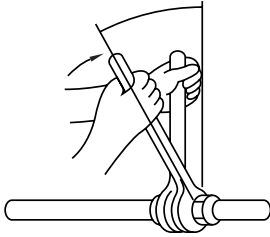

Fig. 5-10

- Apply a thin coat of refrigeration oil on the seat surface of pipe. (Fig. 5-10)
- For connection first align the center, then tighten the first 3 to 4 turns of flare nut.
- Use tightening torque table below as a guideline for indoor unit side union joint section, and tighten using two wrenches. Excessive tightening damages the flare section.

Copper pipe O.D. (mm)	Flare nut O.D. (mm)	Tightening torque (N-m)
ø6.35	17	14 - 18
ø9.52	22	34 - 42
ø12.7	26	49 - 61

**Warning:**

**Be careful of flying flare nut! (Internally pressurized)**

**Remove the flare nut as follows:**

1. Loosen the nut until you hear a hissing noise.
2. Do not remove the nut until the gas has been completely released (i.e., hissing noise stops).
3. Check that the gas has been completely released, and then remove the nut.

### 5.5. Purging procedures leak test

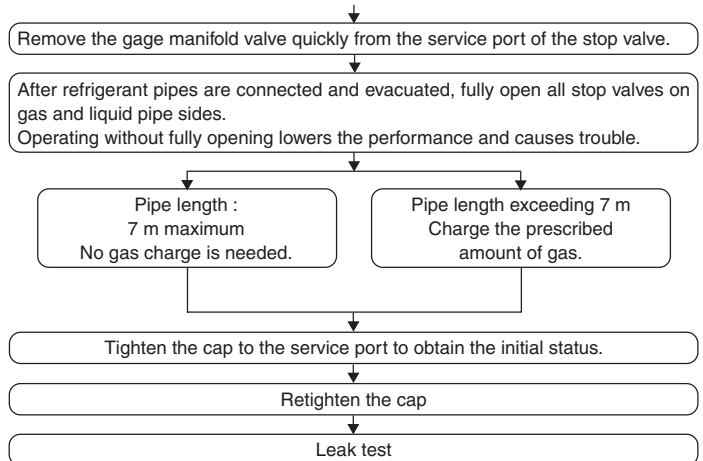
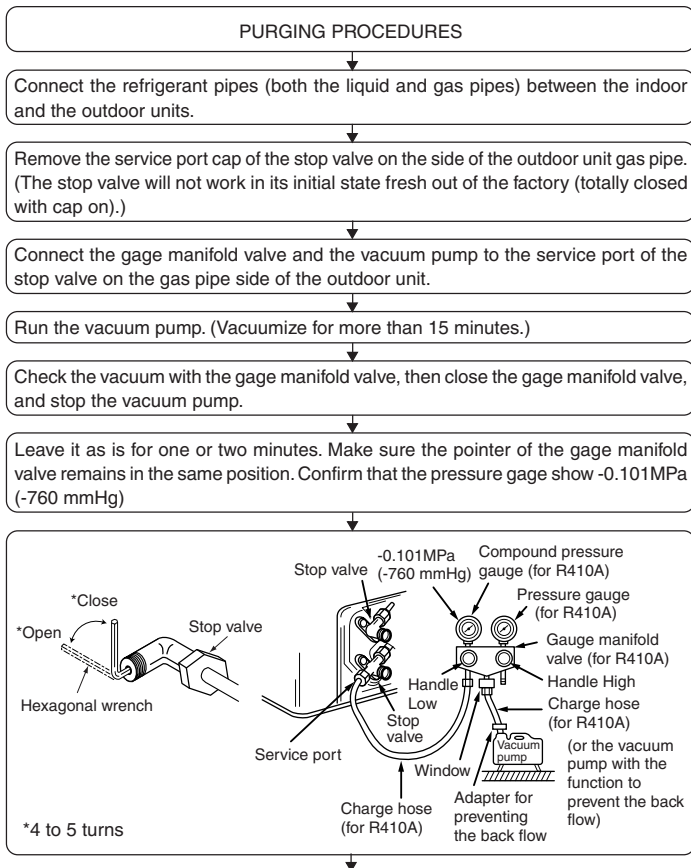

## 6. Drainage piping work

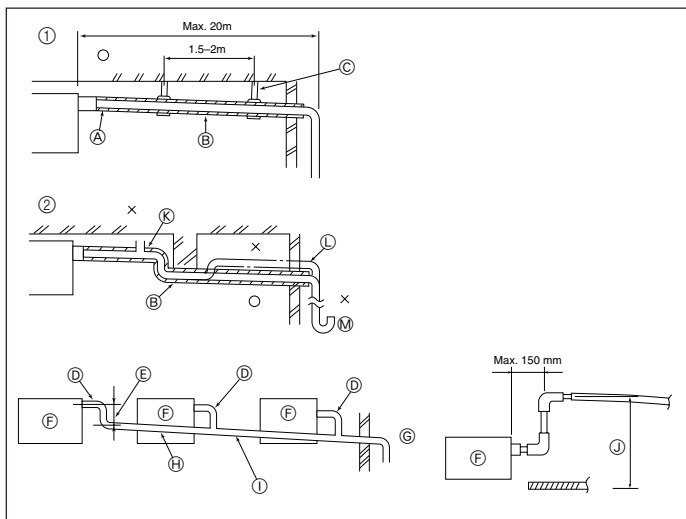

Fig. 6-1

### 6.1. Drainage piping work (Fig. 6-1)

- Use VP25 (O. D. ø32 PVC TUBE) for drain piping and provide 1/100 or more downward slope.
- Be sure to connect the piping joints using a polyvinyl type adhesive.
- Observe the figure for piping work.
- Use the included drain hose to change the extraction direction.

- ① Correct piping
- ② Wrong piping
- Ⓐ Insulation (9 mm or more)
- Ⓑ Downward slope (1/100 or more)
- Ⓒ Support metal
- Ⓚ Air bleeder
- Ⓛ Raised
- Ⓜ Odor trap

**Grouped piping**

- ① O. D. ø32 PVC TUBE
- Ⓔ Make it as large as possible
- Ⓕ Indoor unit
- Ⓖ Make the piping size large for grouped piping.
- Ⓗ Downward slope (1/100 or more)
- ① O. D. ø38 PVC TUBE for grouped piping. (9 mm or more insulation)
- Ⓙ Up to 500 mm

## 6. Drainage piping work

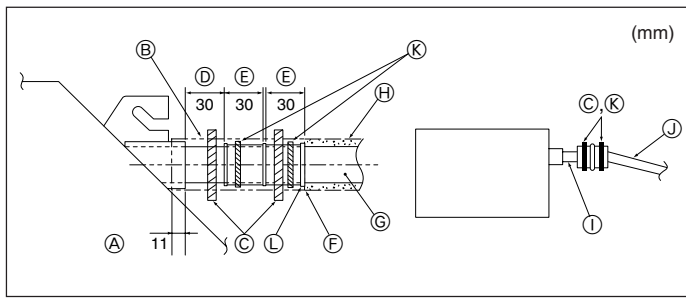

Fig. 6-2

1. Connect the drain socket (supplied with the unit) to the drain port. (Fig. 6-2) (Affix the tube using PVC adhesive then secure it with a band.)
2. Install a locally purchased drain pipe (PVC pipe, O.D.  $\phi 32$ ). (Affix the pipe using PVC adhesive then secure it with a band.)
3. Insulate the tube and pipe. (PVC pipe, O.D.  $\phi 32$  and socket)
4. Check that drain flows smoothly.
5. Insulate the drain port with insulating material, then secure the material with a band. (Both insulating material and band are supplied with the unit.)

- Ⓐ Main unit
- Ⓑ Insulating material
- Ⓒ Band (large)
- Ⓓ Drain port (transparent)
- Ⓔ Insertion margin
- Ⓕ Matching
- Ⓖ Drain pipe (O.D.  $\phi 32$  PVC TUBE)
- Ⓗ Insulating material (purchased locally)
- Ⓙ Transparent PVC pipe
- Ⓚ O.D.  $\phi 32$  PVC TUBE (Slope 1/100 or more)
- Ⓛ Band (small)
- Ⓜ Drain socket

## 7. Electrical work

(1) SLZ-A09/A12 (1:1 SYSTEM)

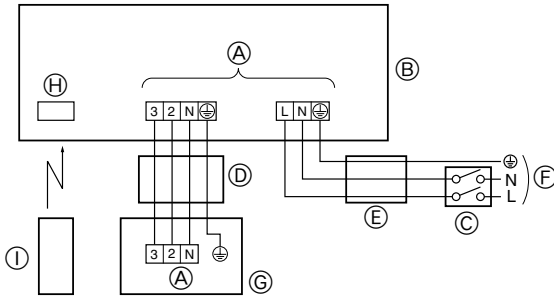

(2) SLZ-A18 (1:1 SYSTEM) OR MULTI SYSTEM

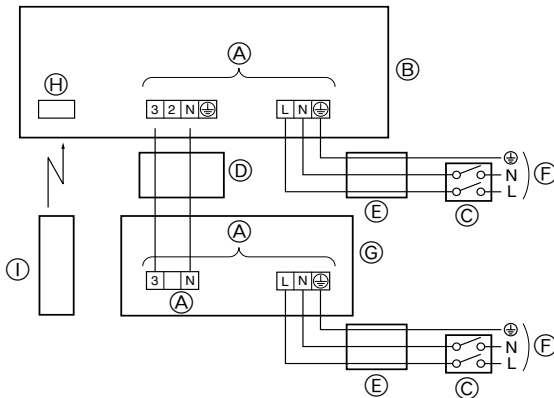

Fig. 7-1

### 7.1. Power supply (Fig. 7-1)

Electrical specification	Input capacity Main Switch/Fuse (A)		
	SLZ-A09	SLZ-A12	SLZ-A18
Power supply (1 phase ~/N, 220-240V, 50Hz)	10	10	20

#### ⚠ Warning:

- Do not use intermediate connection of the power cord, etc. or an extension cord or connect many devices to one AC outlet. It could cause a fire or electric shock due to defective contact, defective insulation, exceeding the permissible current, etc.
- Supply power should be taken from independently branched circuit. If not, it could cause a fire.
- A switch with at least 3 mm contact separation in each pole shall be provided by the air conditioner installation.

- Ⓐ Terminal block
- Ⓑ Indoor unit (Refer to 7-2)
- Ⓒ Breaker
- Ⓓ 4-core cable ((2) ... 2-core cable)
- Ⓔ 3-core cable
- Ⓕ Power supply
- Ⓖ Outdoor unit (Refer to 7-3)
- Ⓗ Receiver
- Ⓚ Wireless remote controller

### 7.2. Indoor unit (Fig. 7-2)

#### Work procedure

1. Remove 2 screws to detach the electric component cover.
  2. Route each cable through the wiring intake into the electric component box. (Procure power supply cable and indoor/outdoor connecting cable locally.)
  3. Securely connect the power supply cable and the indoor/outdoor connecting cable to the terminal blocks.
  4. Secure the cables with clamps outside the electric component box.
  5. Attach the electric component cover as it was.
- Fix power supply cable and indoor/outdoor connecting cable to electric component box by using buffer bushing for tensile force. (PG connection or the like.)

#### ⚠ Warning:

- Attach the electric component cover securely. If it is attached incorrectly, it could result in a fire, electric shock due to dust, water, etc.
- Use the specified indoor/outdoor unit connecting cable to connect the indoor and outdoor units and fix the cable to the terminal block securely so that no stress is applied to the connecting section of the terminal block. Incomplete connection or fixing of the cable could result in a fire.

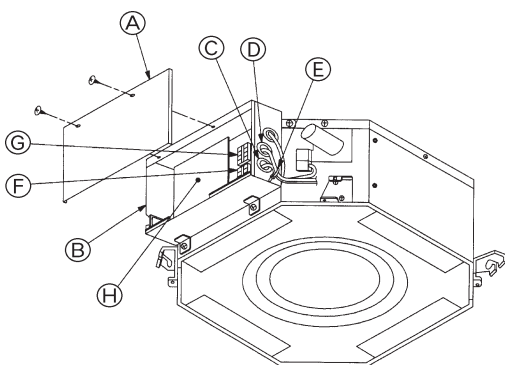

- Ⓐ Electric component cover
- Ⓑ Electric component box
- Ⓒ Entry for power supply cable
- Ⓓ Entry for Indoor/Outdoor connecting cable
- Ⓔ Cable clamp
- Ⓕ Power supply terminals
- Ⓖ Indoor/Outdoor unit connecting terminals
- Ⓗ Indoor controller

Fig. 7-2

## 7. Electrical work

(1) SLZ-A09/A12 (1:1 SYSTEM)

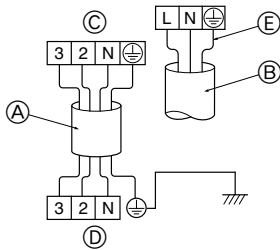

(2) SLZ-A18 (1:1 SYSTEM) OR MULTI SYSTEM

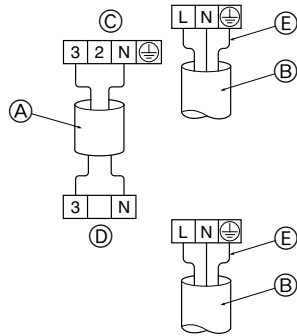

Fig. 7-3

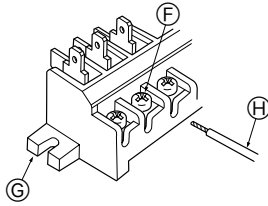

Fig. 7-4

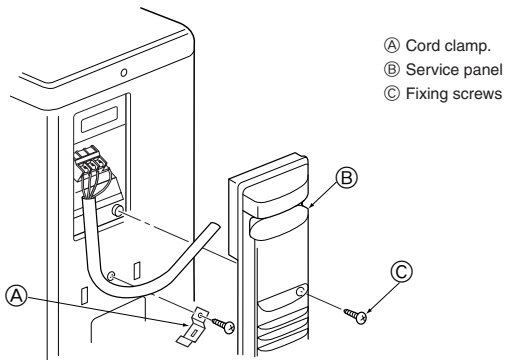

Fig. 7-5

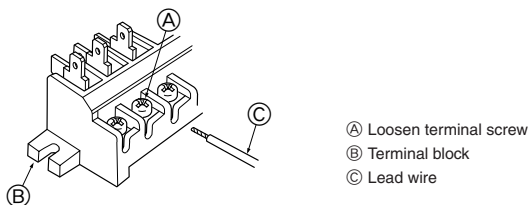

Fig. 7-6

- Perform wiring as shown in the diagram to the lower left. (Procure the cable locally) (Fig. 7-3)

Make sure to use cables of the correct polarity only.

Ⓐ Connecting cable (4 core) ((2) ... 2 core)

Ⓑ Power supply cable (3 core)

• SLZ-A09/A12 : 1.0 mm<sup>2</sup> or more

• SLZ-A18 : 1.5 mm<sup>2</sup> or more

\* Power supply cable and Indoor unit/Outdoor unit connecting cable shall not be lighter than polychloroprene sheathed flexible cord. (design 245 IEC 57)

Ⓒ Indoor terminal block

Ⓓ Outdoor terminal block

Ⓔ Always install an earth, longer than other cable.

- Connect the terminal blocks as shown in the diagram below. (Fig. 7-4)

Ⓕ Loosen terminal screw

Ⓖ Terminal block

Ⓗ Lead wire

⚠ **Caution:**

- Use care not to make mis-wiring.
- Firmly tighten the terminal screws to prevent them from loosening.
- After tightening, pull the wires lightly to confirm that they do not move.

### 7.3. Outdoor unit (Fig. 7-5)

- Connect cable from the indoor unit correctly on the terminal-block.
- Use the same terminal block and polarity as is used with the indoor unit.
- For aftercare maintenance, give extra length to connecting cable.

- Both end of connecting cable (extension wire) are peeled off. When too long, or connected by cutting off the middle, peel off power supply cable to the size given in the figure.
- Be careful not to contact connecting cable with piping.

⚠ **Caution:**

- Use care not to make mis-wiring. (Fig. 7-6)
- Firmly tighten the terminal screws to prevent them from loosening.
- After tightening, pull the wires lightly to confirm that they do not move.

⚠ **Warning:**

- Be sure to attach the service panel of the outdoor unit securely. If it is not attached correctly, it could result in a fire or an electric shock due to dust, water, etc.
- Tighten terminal screws securely.
- Wiring should be done so that the power lines are not subject to tension. Otherwise, heat may be generated or fire may occur.

## 8. Installing the grille

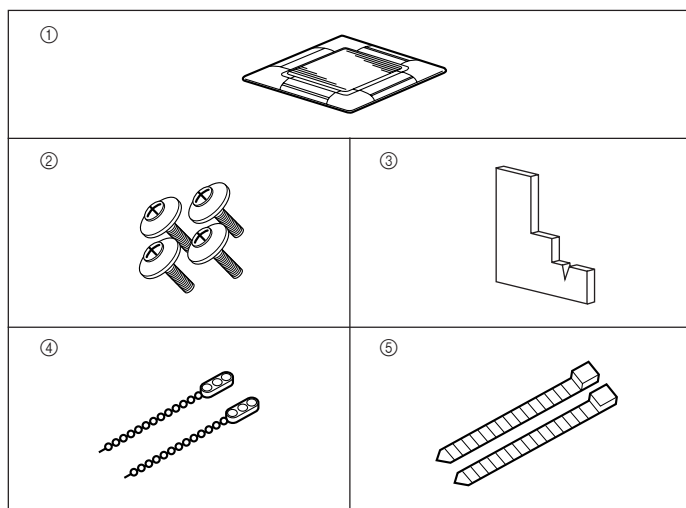

Fig. 8-1

### 8.1. Check the grille accessories (Fig. 8-1)

- The grille should be supplied with the following accessories.

	Accessory name	Q'ty	Remark
①	Grille	1	650 × 650 (mm)
②	Screw with washer	4	M5 × 0.8 × 25 (mm)
③	Gauge	1	
④	Fastener	2	
⑤	Band	2	

## 8. Installing the grille

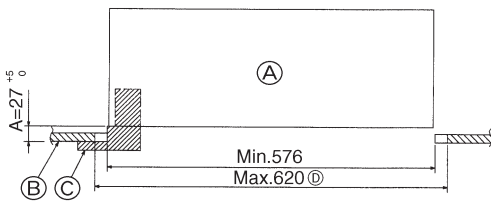

Fig. 8-2

### 8.2. Preparing to attach the grille (Fig. 8-2)

- With the gauge supplied with this kit, adjust and check the positioning of the unit relative to the ceiling. If the unit is not properly positioned in the ceiling, there may be air leaks, condensation may form, or the up/down vanes may not operate correctly.
- Make sure that the opening in the ceiling is within the following tolerances: 576 × 576 - 620 × 620
- Make sure that step A is performed within 27-32 mm. Damage could result by failing to adhere to this range.

- Ⓐ Main unit
- Ⓑ Ceiling
- Ⓒ Gauge (Accessory)
- Ⓓ Ceiling opening dimensions

#### 8.2.1. Removing the intake grille (Fig. 8-3)

- Slide the levers in the direction indicated by the arrow ① to open the intake grille.
- Unlatch the hook that secures the grille.
  - \* Do not unlatch the hook for the intake grille.
- With the intake grille in the "open" position, remove the hinge of the intake grille from the grille as indicated by the arrow ②.

#### 8.2.2. Removing the corner panel (Fig. 8-4)

- Remove the screw from the corner of the corner panel. Slide the corner panel as indicated by the arrow ① to remove the corner panel.

- Ⓐ Intake grille
- Ⓑ Grille
- Ⓒ Intake grille levers
- Ⓓ Grille hook
- Ⓔ Hole for the grille's hook
- Ⓕ Corner panel
- Ⓖ Screw

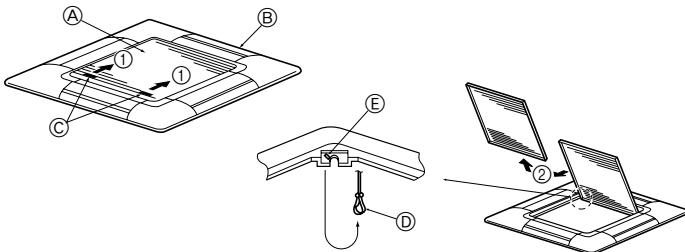

Fig. 8-3

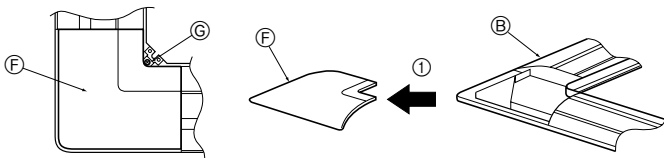

Fig. 8-4

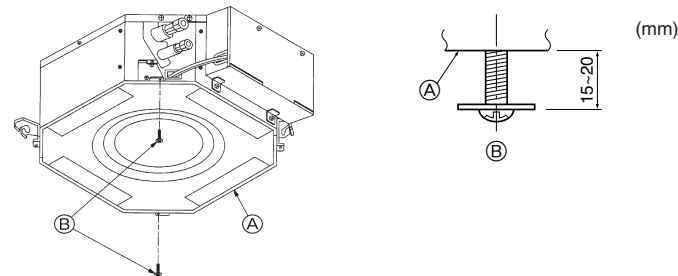

Fig. 8-5

### 8.3. Installing the grille

- Please pay attention because there is a restriction in the attachment position of the grille.

#### 8.3.1. Preparations (Fig. 8-5)

- Install the two enclosed screws with washer in the main unit (at the corner refrigerant pipe area and at the opposite corner) as shown in the diagram.

- Ⓐ Main unit
- Ⓑ Detailed diagram of installed screw with washer (accessory).

#### 8.3.2. Temporary installation of the grille (Fig. 8-6)

- Align the electric component box of the main unit and the receiver of the grille, and then temporarily secure the grille using the bell shaped holes.

\* Make sure that the lead wiring of the grille does not get pinched between the grille and the main unit.

- Ⓐ Main unit
- Ⓑ Electric component box
- Ⓒ Screw with washer (for temporary use)
- Ⓓ Screw with washer (Accessory)
- Ⓔ Grille
- Ⓕ Bell shaped hole
- Ⓖ Receiver

#### 8.3.3. Securing the grille (Fig. 8-7)

- Secure the grille to the main unit by tightening the previously installed two screws (with captive washer) as well as the two remaining screws (with captive washer).

\* Make sure that there are no gaps between the main unit and the grille or the grille and the ceiling.

- Ⓐ Ceiling
- Ⓑ Main unit
- Ⓒ Grille
- Ⓓ Make sure that there are no gaps.

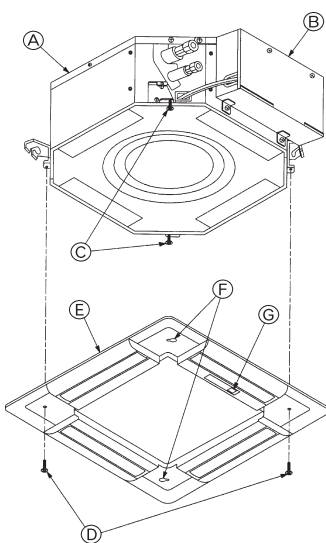

Fig. 8-6

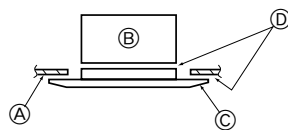

Fig. 8-7

## 8. Installing the grille

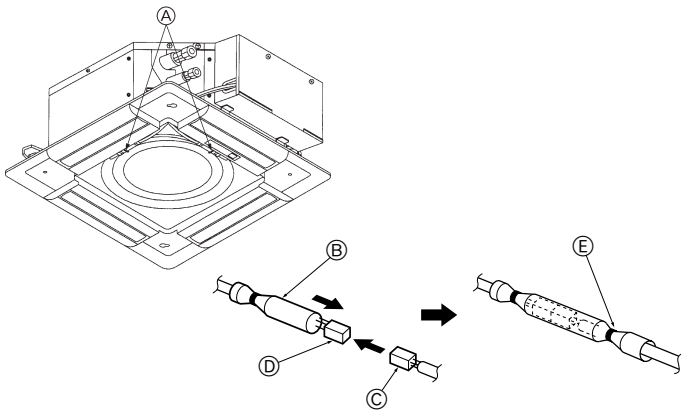

Fig. 8-8

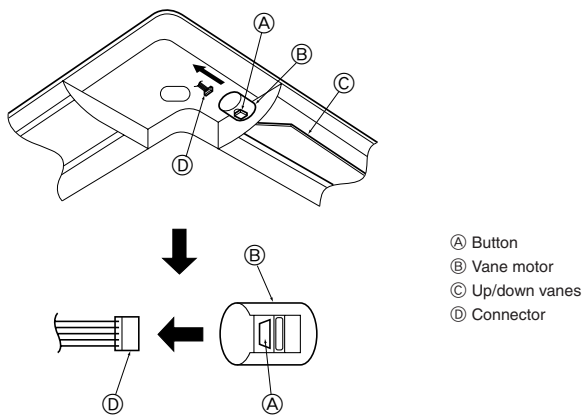

Fig. 8-9

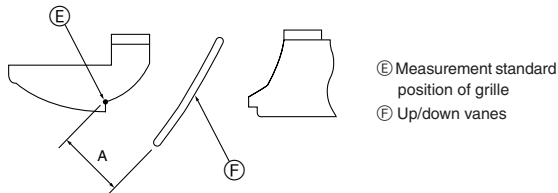

Fig. 8-10

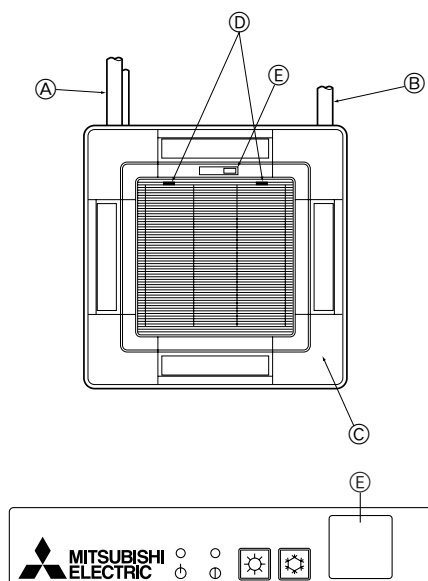

Fig. 8-11

### 8.3.4. Wire connection (Fig.8-8)

- Be sure to connect the unit to the connector (white:10-pole/red:9-pole). Next, attach the white glass tube that comes with the main unit so that the tube covers the connector. Close the opening of the glass tube with the band.
- Make sure that there is no slack in the each lead wire at the fastener on the grille.
  - Ⓐ Fastener (Accessory)
  - Ⓑ White glass tube
  - Ⓒ Connector of the main unit
  - Ⓓ Connector of the grille
  - Ⓔ Band (Accessory)

### 8.4. Locking the up/down airflow direction (Fig. 8-9)

The vanes of the unit can be set and locked in up or down orientations depending upon the environment of use.

- Set according to the preference of the customer.
- The operation of the fixed up/down vanes and all automatic controls cannot be performed using the remote controller. In addition, the actual position of the vanes may differ from the position indicated on the remote controller.
- ① Turn off the main power switch.
  - Injuries and or an electrical shock may occur while the fan of the unit is rotating.
- ② Disconnect the connector for the vane motor of the vent that you want to lock. (While pressing the button, remove the connector in the direction indicated by the arrow as shown in the diagram.) After removing the connector, insulate it with tape.
- ③ To adjust the desired airflow direction, slowly move the up/down vanes within the specified range. (Fig.8-10)

#### Specified range

Up/down airflow direction	Horizontal 30°	Downward 45°	Downward 55°	Downward 70°
A (mm)	21	25	28	30

- The vanes can be set between 21 and 30 mm.

#### ⚠ Caution:

Do not set the up/down vanes passed the specified range. Condensation could form on and drop from the ceiling, or the unit could malfunction.

### 8.5. Installing the intake grille (Fig. 8-11)

- Perform the procedure that is described in "8.2 Preparing to attach the grille" in reverse order to install the intake grille and the corner panel.
  - Ⓐ Refrigerant piping of the main unit
  - Ⓑ Drain piping of the main unit
  - Ⓒ Corner panel
  - \* Installation in any position is possible.
  - Ⓓ Position of the levers on the intake grille when sent from the factory.
  - \* Although the clips can be installed in any of four positions.
  - Ⓔ Receiver

### 8.6. Check

- Make sure that there is no gap between the unit and the grille, or between the grille and the surface of the ceiling. If there is any gap between the unit and the grille, or between the grille and the surface of the ceiling, it may cause dew to collect.
- Make sure that the wires have been securely connected.

## 9. Installing the remote controller

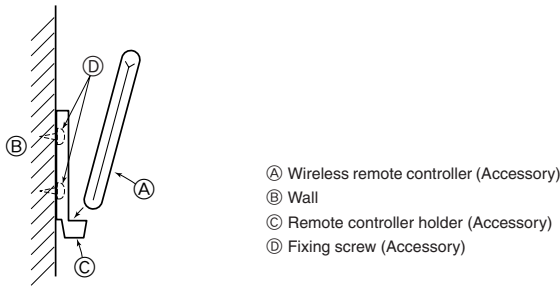

Fig. 9-1

### 9.1. Wireless remote controller (Fig. 9-1)

#### 9.1.1. Installation area

- Area in which the remote controller is not exposed to direct sunshine.
- Area in which there is no nearby heating source.
- Area in which the remote controller is not exposed to cold (or hot) winds.
- Area in which the remote controller can be operated easily.
- Area in which the remote controller is beyond the reach of children.

#### 9.1.2. Installation method

- ① Attach the remote controller holder to the desired location using two tapping screws.
  - ② Place the lower end of the controller into the holder.
- The signal can travel up to approximately 7 meters (in a straight line) within 45 degrees to both right and left of the center line of the receiver. In addition, the signal may not be received if there is interference of light of fluorescent lights or strong sunlight.

## 10. Test run

### 10.1. Before test run

- ▶ After installation of indoor and outdoor units, and piping and electric wiring work, re-check that the unit is free from leaks of refrigerant, loosened connections, and incorrect polarity.
- ▶ Measure an impedance between the power supply terminal block (L, N, ⊕) on the units and the ground with a 500 V Megger and check that it is equal to or greater than 1.0 MΩ.

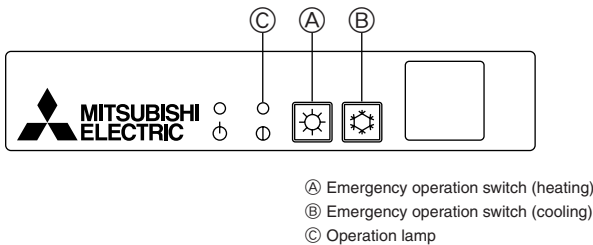

Fig. 10-1

### 10.2. AUTO RESTART FUNCTION

#### Indoor controller board

This model is equipped with the AUTO RESTART FUNCTION.

When the indoor unit is controlled with the remote controller, the operation mode, set temperature, and the fan speed are memorized by the indoor controller board. The auto restart function sets to work the moment the power has restored after power failure, then, the unit will restart automatically.

### 10.3. Test run (Fig. 10-1)

Measure an impedance between the power supply terminal block on the outdoor unit and the ground with a 500 V Megger and check that it is equal to or greater than 1.0 MΩ.

- Before performing the test run, recheck for any wrong wiring. Wrong wiring prevents normal operation or results in blown fuse disabling operation.
- The test run can be started by pressing emergency operation switch (cooling/heating). When the emergency operation switch is once pressed, the unit will start the test run (continuous operation) for 30 minutes. A thermostat does not work during this time. After 30 minutes the unit will start the emergency operation at a fixed temperature setting of 24°C in cooling mode or heating mode.
- Perform test run in the following procedure.

#### Procedure

- ① Press the ❄️ button (B) to start the cooling operation.

If the operation lamp (C) blinks every 0.5 seconds, inspect the indoor/outdoor connecting wire for mis-wiring.

- Check that the vanes operate properly when cool air is blown out.
- ② Press it once more, and the operation stops.
- ③ Press the ☀️ button (A) to start the heating operation. Check that warm air blows out.
- In starting the heating operation, indoor unit fan may not operate to prevent blowing cool air. Please wait for a few minutes until the temperature of heat exchanger rises and warm air blows out.
- ④ Press it once more, and the operation stops.

#### Checking the remote (infrared) signal reception

Press the ON/OFF button on the remote controller and check that an electronic sound is heard from the indoor unit. Press the ON/OFF button again to turn the air conditioner off.

**If the indoor unit is operated with the remote controller, both the test run and the emergency operation are released by commands from the remote controller.**

Once the compressor stops, the restart preventive device operates so the compressor will not operate for three minutes to protect the air conditioner.

### 10.4. Check drainage (Fig. 10-2)

- During the test run, ensure the water is being properly drained out and that no water is leaking from joints.
  - Always check this during installation even if the unit is not required to provide cooling/drying at that time.
  - Similarly, check the drainage before finishing ceiling installation in a new premises.
- (1) Remove the cover of the water supply inlet and add about 1000 cc of water using a water supply pump etc. During this process, be careful not to spray water into the drain pump mechanism.
  - (2) Switching on emergency operation switch (cooling) on the grille.
  - (3) Confirm that water is being drained out through the drainage outlet.
  - (4) After checking the drainage, ensure that the cover is replaced and the power supply is isolated.
  - (5) After confirming the drainage system is functioning, replace the drain plug.

- A Insert the pump end 3 to 5 cm  
 B Cover of water supply inlet  
 C About 1000 cc  
 D Water  
 E Drain plug  
 F Emergency operation switch (cooling)

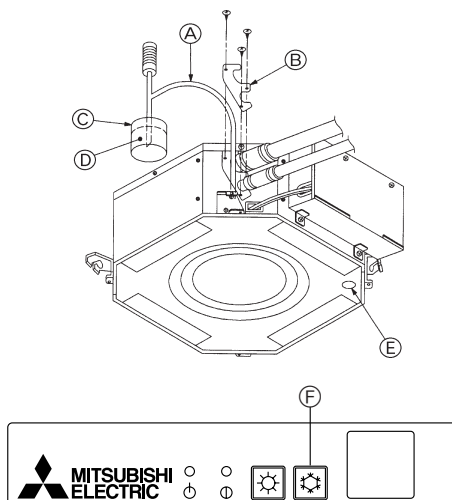
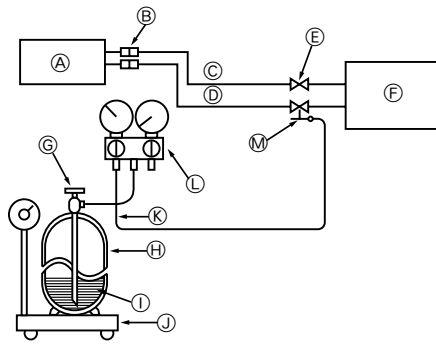

Fig. 10-2

## 11. Maintenance



- |  |  |
|--|--|
| Ⓐ Indoor unit                              | Ⓜ Refrigerant gas cylinder for R410A with siphon |
| Ⓑ Union                                    | Ⓨ Refrigerant (liquid)                           |
| Ⓒ Liquid pipe                              | Ⓩ Electronic scale for refrigerant charging      |
| Ⓓ Gas pipe                                 | ⓐ Charge hose (for R410A)                        |
| Ⓔ Stop valve                               | Ⓛ Gauge manifold valve (for R410A)               |
| Ⓕ Outdoor unit                             | Ⓜ Service port                                   |
| Ⓖ Refrigerant gas cylinder operating valve |  |

**Fig. 11-1**

### 11.1. Gas charge (Fig. 11-1)

1. Connect gas cylinder to the service port of stop valve (3-way).
2. Execute air purge of the pipe (or hose) coming from refrigerant gas cylinder.
3. Replenish specified amount of refrigerant, while running the air conditioner for cooling.

**Note:**

In case of adding refrigerant, comply with the quantity specified for the refrigerating cycle.

**⚠ Caution:**

- Do not discharge the refrigerant into the atmosphere. Take care not to discharge refrigerant into the atmosphere during installation, reinstallation, or repairs to the refrigerant circuit.
- For additional charging, charge the refrigerant from liquid phase of the gas cylinder. If the refrigerant is charged from the gas phase, composition change may occur in the refrigerant inside the cylinder and the outdoor unit. In this case, ability of the refrigerating cycle decreases or normal operation can be impossible. However, charging the liquid refrigerant all at once may cause the compressor to be locked. Thus, charge the refrigerant slowly.

To maintain the high pressure of the gas cylinder, warm the gas cylinder with warm water (under 40°C) during cold season. But never use naked fire or steam.

---

This product is designed and intended for use in the residential,  
commercial and light-industrial environment.

The product at hand is based on the following EU regulations:

- Low Voltage Directive 73/23/ EEC
- Electromagnetic Compatibility Directive 89/336/ EEC

Please be sure to put the contact address/telephone number on  
this manual before handing it to the customer.