

SHARP SERVICE MANUAL

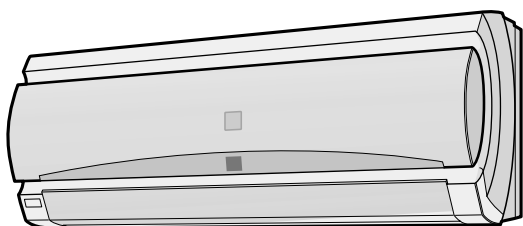

(INDOOR UNIT)

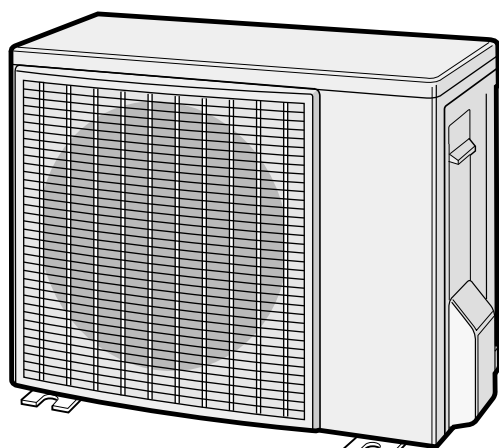

(OUTDOOR UNIT)

MODEL

SPLIT TYPE ROOM AIR CONDITIONERS

INDOOR UNIT

MODELS **AY-XP07ER**

AY-XP09ER

AY-XP12ER

OUTDOOR UNIT

AE-X07ER

AE-X09ER

AE-X12ER

In the interests of user-safety (Required by safety regulations in some countries) the set should be restored to its original condition and only parts identical to those specified should be used.

TABLE OF CONTENTS

	Page
SPECIFICATIONS	2
EXTERNAL DIMENSIONS	3
WIRING DIAGRAMS	4
ELECTRICAL PARTS	5
REFRIGERATION CYCLE	6
PERFORMANCE CURVES	7
REPLACEMENT PARTS LIST	
AY-XP07ER / AY-XP09ER / AY-XP12ER	8
AE-X07ER / AE-X09ER / AE-X12ER	11

SPECIFICATIONS

ITEMS	MODEL	INDOOR UNIT	OUTDOOR UNIT	INDOOR UNIT	OUTDOOR UNIT	INDOOR UNIT	OUTDOOR UNIT
		AY-XP07ER	AE-X07ER	AY-XP09ER	AE-X09ER	AY-XP12ER	AE-X12ER
Cooling capacity(Min. ~ Max.)	kW	2.1 (0.9 – 3.0)		2.6 (0.9 – 3.0)		3.5 (0.9 – 4.0)	
Heating capacity(Min. ~ Max.)	kW	3.0 (0.9 – 4.0)		3.6 (0.9 – 5.0)		4.6 (0.9 – 6.0)	
Moisture removal(at cooling)	Liters/h						

Electrical data

Phase		Single						
Rated frequency		Hz	50					
Rated voltage		V	230					
Rated current ★ (Min - Max.)	Cool	A	2.6 (0.8 – 4.6)		3.3 (0.8 – 4.6)		4.6 (0.8 – 6.4)	
	Heat	A	3.7 (0.7 – 6.5)		4.1 (0.7 – 6.5)		5.2 (0.7 – 8.1)	
Rated input ★ (Min - Max.)	Cool	W	510 (150 – 900)		650 (150 – 900)		960 (150 – 1400)	
	Heat	W	730 (130 – 1400)		900 (130 – 1400)		1190 (130 – 1800)	
Power factor ★	Cool	%	85		86		91	
	Heat	%	86		95		99	
Compressor	Type		Hermetically sealed rotary type					
	Model		5RS092XDF					
	Oil charge		320cc (RB68A or Freol Alphc 68M)					
Refrigerant system	Evaporator		Louver Fin and Grooved tube type					
	Condenser		Corrugate Fin and Grooved tube type					
	Control		Expansion valve					
	Refrigerant (R410A)		1000g		1000g		1080g	
	De-Ice system		Micro computer controled reversed systems					
Noise level (at cooling)	High	dB(A)	38	46	43	48	45	49
	Low	dB(A)	32	–	34	–	38	–
	Soft	dB(A)	26	–	28	–	31	–

Fan system

Drive		Direct drive						
Air flow quantity (at cooling)	High	m ³ /min.	7.8	22	9.9	22	11.2	24
	Low	m ³ /min.	6.8	–	7.7	–	9.0	–
	Soft	m ³ /min.	5.2	–	6.0	–	6.8	–
Fan		Cross flow fan	Propeller fan	Cross flow fan	Propeller fan	Cross flow fan	Propeller fan	

Connections

Refrigerant coupling		Flare type					
Refrigerant tube size Gas, Liquid		3/8", 1/4"			1/2", 1/4"		
Drain piping mm		O.D ø 18					

Others

Safety device		Compressor: Thermal protector						
		Fan motors: Thermal fuse						
		Fuse, Micro computer control						
Air filters		Polypropylene net (Washable)						
Net dimensions	Width	mm	810	730	810	730	810	780
	Height	mm	285	540	285	540	285	540
	Depth	mm	240	250	240	250	240	265
Net weight		kg	11	36	11	36	11	37

Note: The condition of star " ★ " marked item are 'ISO5151' : 1994(E), condition T1.

EXTERNAL DIMENSIONS

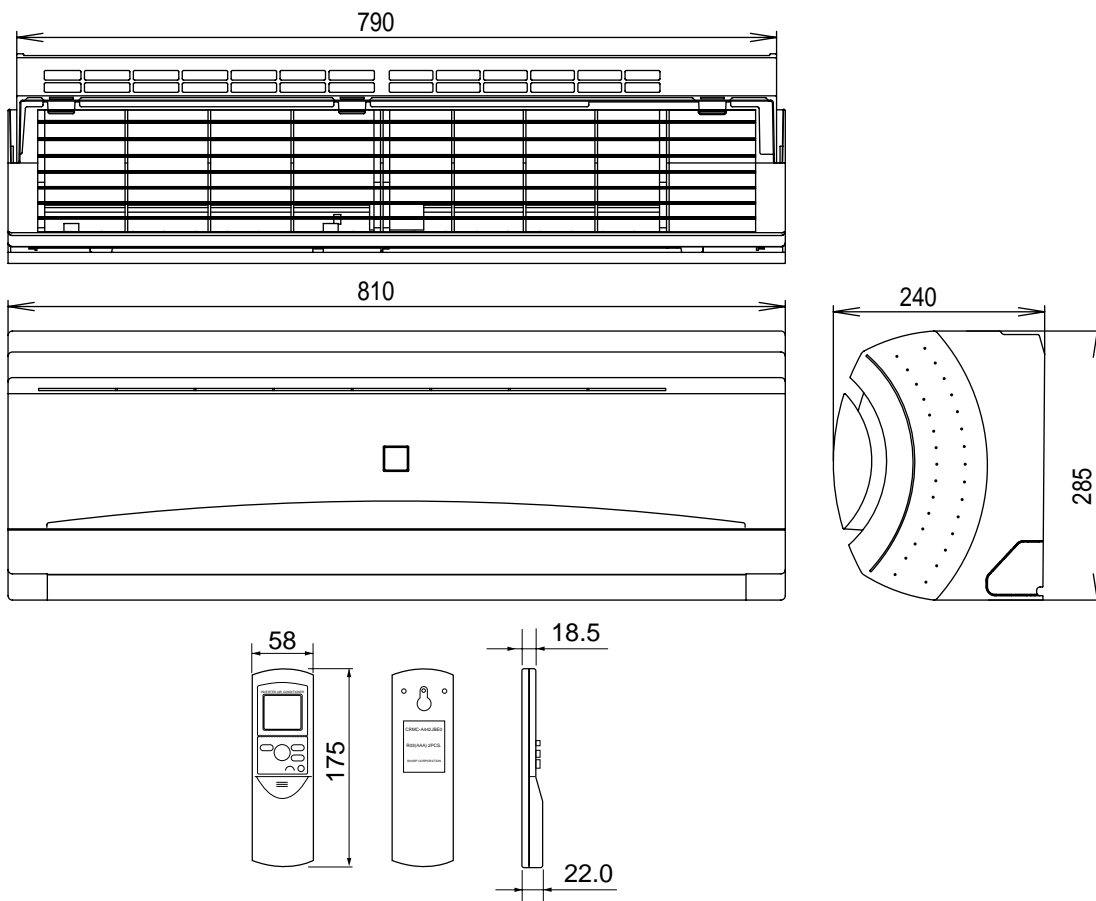

Figure E-1. INDOOR UNIT

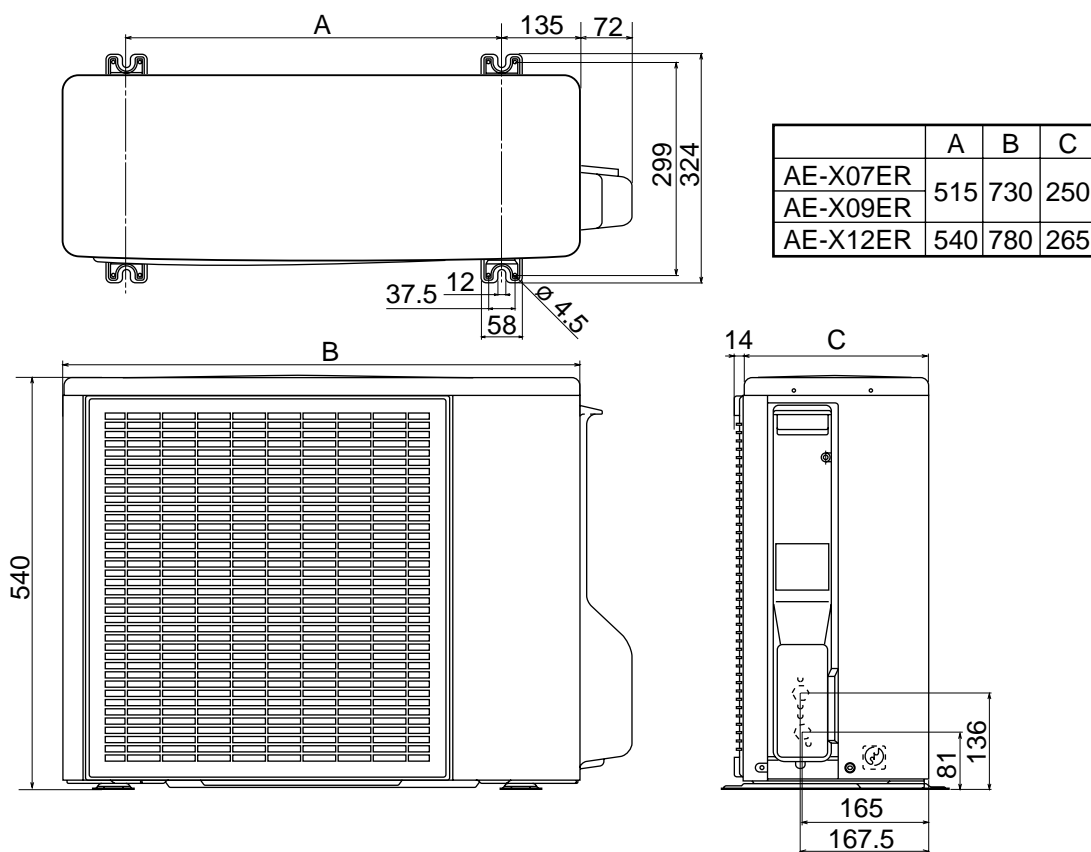

Figure E-2. OUTDOOR UNIT

WIRING DIAGRAMS

LED INDICATION FOR SELF-DIAGNOSIS

Temperature Indicator Blinking No.	Abnormal contents
1	Short circuit of the Thermistor
2	Overheat error (compressor and cycle)
5	Open circuit of the Thermistor
6	Abnormal DC current
7	Abnormal AC current
9	Abnormal Thermistor or four way valv
11	Abnormal outdoor fan motor
13	Rotation error of the compressor or compressor lock
14	Abnormal PAM voltage and PAM clock signal
17	Open circuit of serial signal line
18	Short circuit of serial signal line
19	Abnormal fan motor of indoor unit

<Indication of the abnormal condition>
 LED indicator will blink, if the set is in abnormal condition.

WIRING DIAGRAM <CB878>

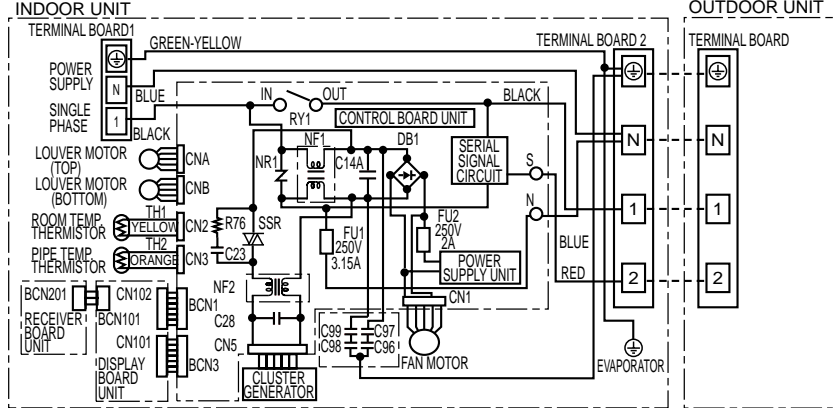
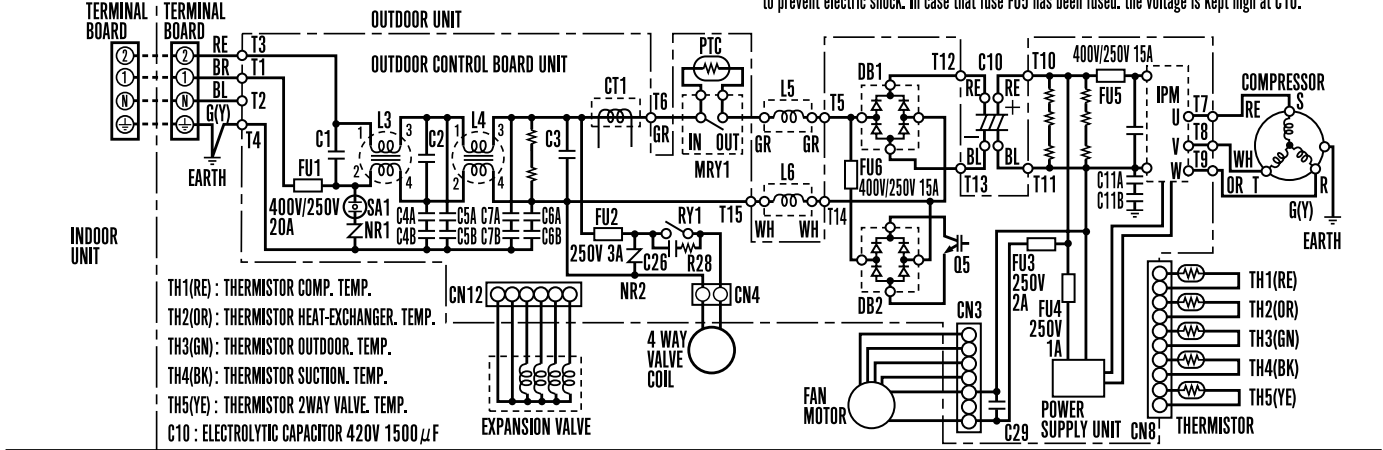

Figure W-1. Wiring Diagram for AY-XP07ER / AY-XP09ER / AY-XP12ER

WIRING DIAGRAM <CB879>

CAUTION

The voltage is high at C10 (electrolytic capacitor) on outdoor unit. For mentenance discharge at C10 to prevent electric shock. In case that fuse FU5 has been fused, the voltage is kept high at C10.



LED INDICATION SELF-DIAGNOSIS ON OUTDOOR UNIT

No.	LED Indication pattern	Abnormal comments
	○	Normal
1	●	Abnormal signal line
2	○ × 1 time	Short circuit of the Thermistor
3	○ × 2 times	Overheat error (compressor and cycle)
4	○ × 5 times	Open circuit of the Thermistor
5	○ × 6 times	Abnormal DC current
6	○ × 7 times	Abnormal AC current

No.	LED Indication pattern	Abnormal comments
7	○ × 9 times	Abnormal Thermistor or four way valve
8	○ × 11 times	Abnormal outdoor fan motor
9	○ × 13 times	Rotation error of the compressor or compressor lock
10	○ × 14 times	Abnormal PAM voltage and PAM clock signal

LED BLINKING	
●	LED turns on
○	Slow flashing (1 time for 1 second)
○	Quick flashing (3 times for 1 second)

Example : No.3 Overheat error (Compressor and cycle)

⚠ DANGER-HIGH VOLTAGE

The micro computer's GND line which control the thermistor, etc., share the same line of 280V line. Do not touch the control circuit components as it may result in electrical shock hazard.

Do not earth oscilloscope, etc., as it may become damaged.

Figure W-2. Wiring Diagram for AE-X07ER / AE-X09ER / AE-X12ER

ELECTRICAL PARTS

For Model AY-XP07ER / AY-XP09ER / AY-XP12ER

DESCRIPTION	MODEL	REMARKS
Indoor fan motor	MLB084	DC Motor
Indoor fan motor capacitor	-	-
Transformer	-	-
FUSE1	-	QFS-GA052JBZZ (250V, 3.15A)
FUSE2	-	QFS-GA051JBZZ (250V, 2A)

For Model AE-X07ER / AE-X09ER / AE-X12ER

DESCRIPTION	MODEL	REMARKS
Compressor	5RS092XDF	D.C. brush-less motor
Outdoor fan motor	ML-A902	DC Motor
Outdoor fan motor capacitor	-	-
WPE1	-	QFS-GA050JBZZ(250V, 1A)
WPE101	-	QFS-GA051JBE0(250V, 2A)
WPE3	-	QFS-GA052JBZZ(250V, 3.15A)
WPE5	-	QFS-GA065JBZZ(400V, 20A)
	-	QFS-GA066JBZZ(400V, 15A)

REFRIGERATION CYCLE

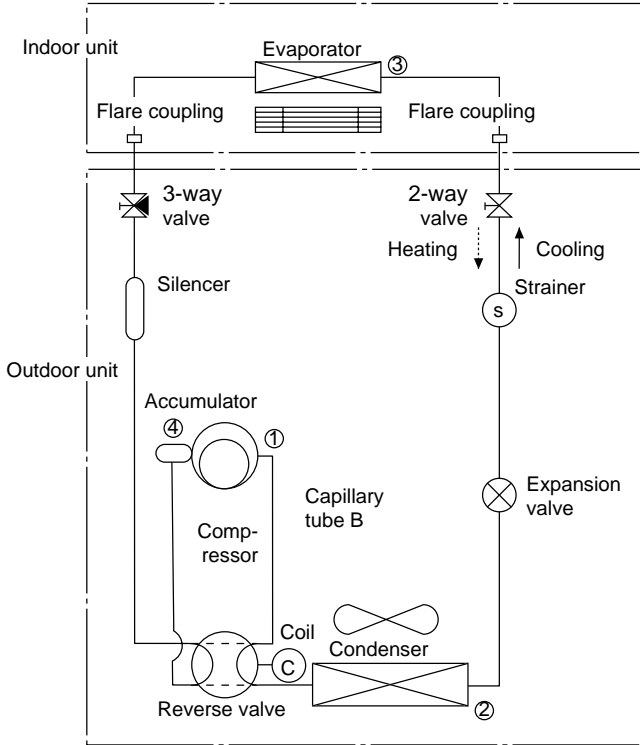

Flow for Refrigerant for AY-XP07ER / AY-XP09ER

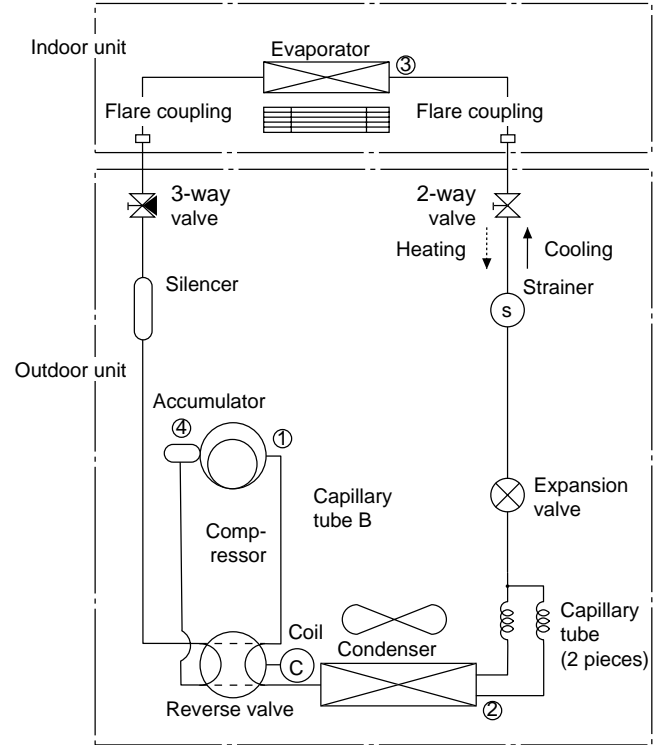

Flow for Refrigerant for AY-XP12ER

Standard conditions:

AY-XP07ER / AY-XP09ER / AY-XP12ER

※ REFRIGERANT PIPE LENGTH 7.5m

	Indoor side		Outdoor side	
	Dry-bulb Temp. (°C)	Relative Humidity (%)	Dry-bulb Temp. (°C)	Relative Humidity (%)
Cooling	27	47	35	40
Heating	20	—	7	87

Temperature at each part and pressure in 3-way valve

Model	AY-XP07ER		AY-XP09ER		AY-XP12ER	
	Cooling	Heating	Cooling	Heating	Cooling	Heating
①	72	78	72	78	74	80
②	40	1	40	1	42	2
③	15	28	15	28	14	30
④	16	2	16	2	14	2
3-way valve pressure (MPaG)	1.00	2.60	1.00	2.60	1.00	2.60

Dimension of Capillary tube

Model	AY-XP12ER		
	O.D	I.D	L
Capillary tube	ø2.7	ø1.7	300

PERFORMANCE CURVES

- NOTE: 1) Indoor fan speed: Hi
 2) Vertical adjustment louver "45°", Horizontal adjustment louver "front"
 3) Indoor air temp. : Cooling 27°C, Heating 20°C
 4) Power source : 230V, 50Hz

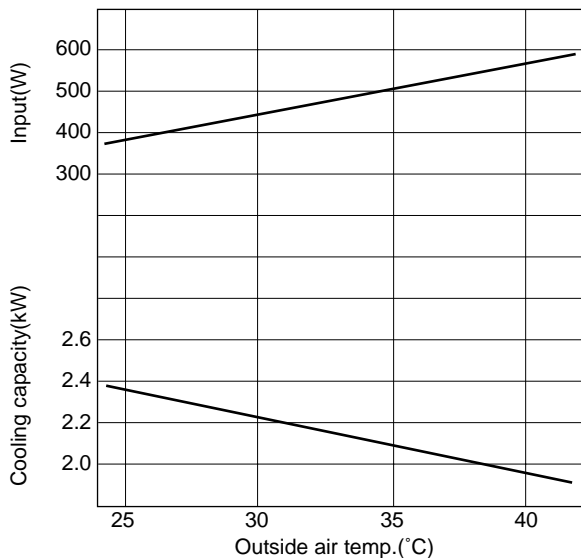

Figure P-1. At Cooling for AY-XP07ER

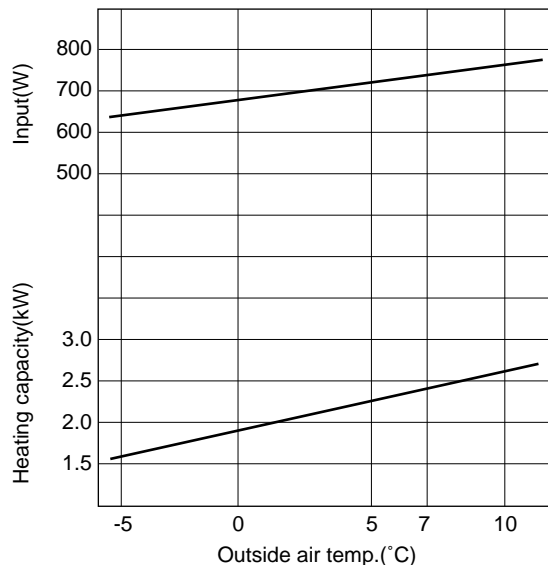

Figure P-2. At Heating for AY-XP07ER

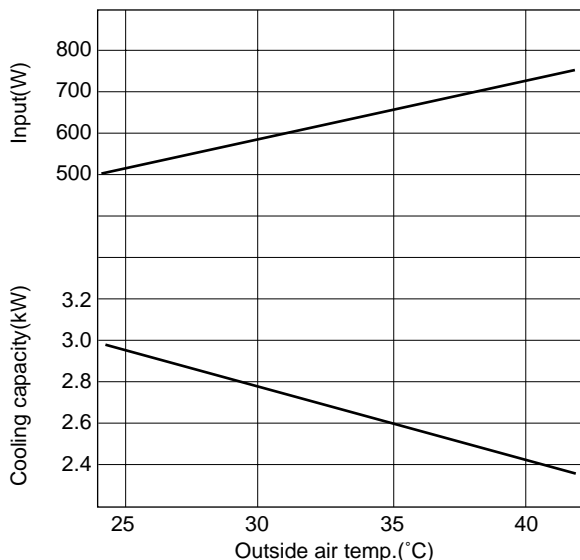

Figure P-3. At Cooling for AY-XP09ER

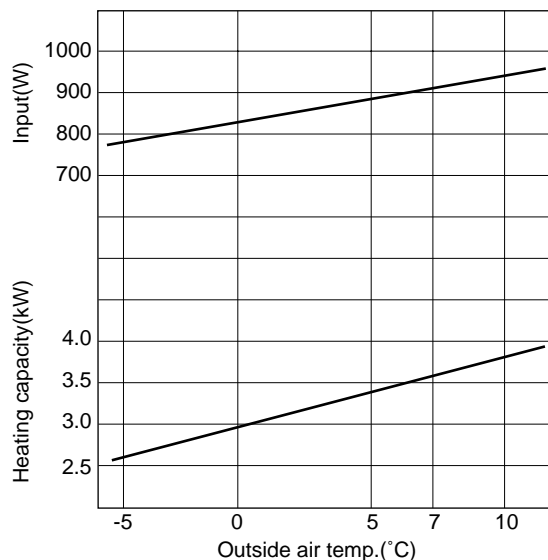

Figure P-4. At Heating for AY-XP09ER

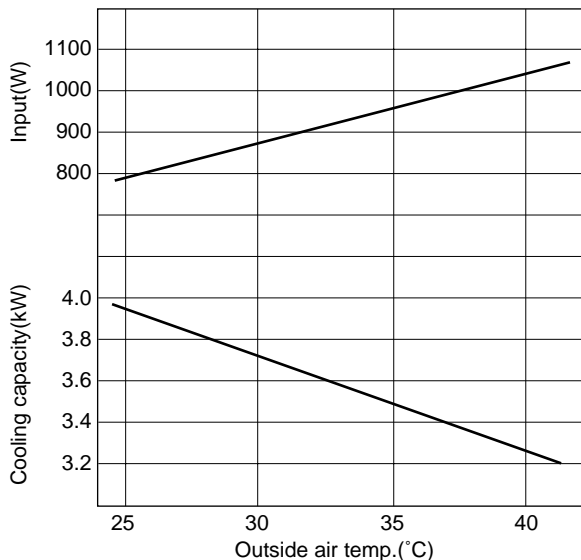

Figure P-5. At Cooling for AY-XP12ER

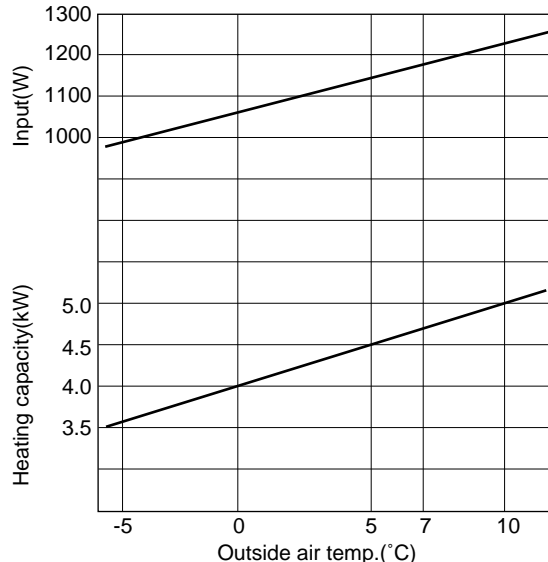

Figure P-6. At Heating for AY-XP12ER

REPLACEMENT PARTS LIST (AY-XP07ER / AY-XP09ER / AY-XP12ER)

REF. NO.	PART NO.	DESCRIPTION	Q'TY	CODE
CONTROLBOX PARTS				
1- 1	CMOT-A433JBKZ	Fan motor sub ass'y	1	BK
1- 2	DSGY-B540JBKZ	Control board unit [AYXP07ER]	1	BU
1- 2	DSGY-B532JBKZ	Control board unit [AYXP09ER]	1	BU
1- 2	DSGY-B550JBKZ	Control board ass'y [AYXP12ER]	1	BU
1- 2-1	QFS-GA051JBZZ	Fuse	1	AD
1- 2-2	QFS-GA052JBZZ	Fuse	1	AD
1- 3	QACC-A298JBZZ	Power supply cord	1	
1- 4	QTANZA001JBZZ	Terminal board	1	AQ
1- 5	QTANZA018JBZZ	Terminal board	1	
1- 6	RH-HXA014JBZZ	Thermister ass'y	1	AG
1- 7	RTHM-A292JBEO	Thermistor	1	AH
1- 8	QW-VZE403JBZZ	Lead wire	1	AH
1- 9	RMOT-A110JBZZ	Louver motor	1	AN
1- 10	RMOT-A108JBEZ	Louver motor-b	1	AN
1- 11	CKITTA013JBKZ	Plasmacluster unit	1	AZ
CABINET AND UNIT PARTS				
2- 1	CHLD-A050JBK0	Bearing ass'y	1	AG
2- 2	PGUMMA206JBE0	Motor cushion	1	
2- 3	PGUMMA207JBE0	Motor cushion	1	
2- 4	DCHS-A502JBKZ	Cabinet ass'y	1	BA
2- 5	PGID-A108JBFA	Guide	1	AL
2- 6	NFANCA087JBKZ	Crossflow fan	1	BA
2- 7	PCOV-A845JBFZ	Motor cover	1	AG
2- 8	CCOV-A093JBKZ	Louver cover ass'y	1	
2- 8-1	FCOV-A155JBFA	Cover	1	
2- 8-2	MHNG-A031JBFA	Cover hinge	1	AC
2- 8-3	PCOV-B005JBFA	Louver cover	1	AF
2- 9	PCOV-A849JBFZ	Side cover	1	AF
2- 10	PGID-A109JBFZ	Guide	2	AF
2- 11	CLOV-A054JBKZ	Direct.louver ass'y	1	AN
2- 11-1	MLOV-A385JBFA	Air direction louver	1	
2- 11-2	NBRG-A030JBFA	Bearing	1	AB
2- 11-3	NBRG-A037JBFA	Bearing	1	AE
2- 12	CPNL-A485JBKZ	Cont.box cover ass'y	1	AQ
2- 13	FCOV-A143JBFZ	Senser cover	1	AD
2- 14	PCOV-A992JBFZ	Led holder	1	AD
2- 15	PCOV-B010JBFA	Led cover	1	
2- 16	LHLD-A449JBF0	Thermistor holder	1	AH
2- 17	LHLD-A690JBFZ	Senser holder	1	BD
2- 18	PBOX-A432JBFZ	Control box	1	BF
2- 19	PCOV-A847JBPZ	Cont.box cover	1	AG
2- 20	CSRA-A577JBKZ	Drain pan ass'y	1	
2- 20-1	CHOS-A015JBKZ	Drain hose ass'y	1	
2- 20-10	MJNTPA095JBFA	Louver link	2	AB
2- 20-11	MLOV-A346JBFA	Vertical louver	9	AB
2- 20-12	MLOV-A347JBFA	Vertical louver	1	AB
2- 20-13	MLOV-A386JBTA	Air flow louver	1	AS
2- 20-14	NBRG-A028JBFA	Bearing	1	AB
2- 20-15	NBRG-A031JBFA	Bearing	1	AC
2- 20-16	NBRG-A038JBFA	Bearing c	1	AC
2- 20-17	PGUMMA169JBE0	Drain plug	1	AD
2- 20-2	DSRA-A258JBKZ	Drain pan sub ass'y	1	
2- 20-3	GGAD-A057JBTA	Wire guard	1	
2- 20-4	PSRA-A161JBFA	Drain pan	1	
2- 20-5	LHLD-A615JBFA	Louver stopper	1	AC
2- 20-6	LHLD-A682JBFA	Led holder	1	AE
2- 20-7	LHLD-A691JBFZ	Lead wire guide	2	AE
2- 20-8	LPFT-A144JBFZ	Dorain joint	1	AD
2- 20-9	LPFT-A147JBFZ	Dorain joint 1	1	

REF. NO.	PART NO.	DESCRIPTION	Q'TY	CODE
2- 21	CPNL-A486JBKZ	Open panel ass'y	1	BC
2- 21-1	HBDG-A144JBEA	Badge	1	AF
2- 21-2	HDECQA097JBRA	Display panel	1	AF
2- 21-3	HDECQA098JBRA	Display panel	1	AX
2- 21-4	HPNL-A672JBTA	Open panel	1	
2- 21-5	LHLD-A680JBFA	Holder	1	AD
2- 21-6	LHLD-A681JBFZ	Display holder	6	AC
2- 22	DWAK-A869JBKZ	Front panel ass'y	1	AS
2- 22-1	GWAK-A300JBFA	Front panel	1	AV
2- 22-2	TLABCB878JBRZ	Wiring diagram	1	AC
2- 23	DHLD-A009JBK0	Pipe holder ass'y	1	AE
2- 24	LHLD-A689JBFA	Holder	1	AG
2- 25	LHLD-A394JBFA	Pipe holder	1	AD
2- 26	PCOV-A848JBFZ	Drain cover	1	AD
2- 27	PCOV-B006JBFA	Screw cover	3	AD
2- 28	PFILMA191JBEZ	Air filter	1	AL
2- 29	PPLTNA078JBPZ	Mounting angle	1	AU
2- 30	TSPC-E666JBRZ	Name badge [AYXP07ER]	1	
2- 30	TSPC-E651JBRZ	Name badge [AYXP09ER]	1	
2- 30	TSPC-E681JBRZ	Name badge [AYXP12ER]	1	AC

CYCLE PARTS

3- 1	CPIPCA796JBKZ	Inlet tube ass'y [AYXP07ER] [AYXP09ER]	1	AX
3- 1	CPIPCA813JBKZ	Inlet tube ass'y [AYXP12ER]	1	
3- 2	DEVA-A189JBKZ	Evaporator ass'y	1	BS
3- 3	LX-NZA169JBE0	Flare nut1/4	1	AG
3- 4	PCAP-A064JBE0	Cap 1/4	1	

ACCESSORY PARTS

4- 1	CFIL-A088JBKZ	Purify filter ass'y	1	AR
4- 2	CRMC-A629JBEZ	Remote control	1	BB
4- 3	FFZK-A178JBKZ	Screws kit	1	
4- 4	LHLD-A688JBFA	Cord holder	1	AE
4- 5	LPFT-A088JBF0	Drain joint	1	AC
4- 6	SSAKHA149YDE0	Bag	1	AC
4- 7	TINS-A811JBRZ	Installation manual1	1	AL
4- 8	TINS-A812JBRZ	Installation manual2	1	AL
4- 9	TINSEA363JBRZ	Operation manual	1	AS
4- 10	UBATUA027JBE0	Battery pack	1	AE

PACKING PARTS

90- 1	CPADBA059JBKZ	Packing pad ass'y	2	AK
90- 2	SPADBA189JBEZ	Pad	1	AD
90- 3	SPAKCB549JBEZ	Packing case [AYXP07ER]	1	
90- 3	SPAKCB537JBEZ	Packing case [AYXP09ER]	1	
90- 3	SPAKCB568JBEZ	Packing case [AYXP12ER]	1	AR

HOW TO ORDER REPLACEMENT PARTS

To have your order filled promptly and correctly, please furnish the following information.

1. MODEL NUMBER 2. REF. NO. 3. PART NO. 4. DESCRIPTION

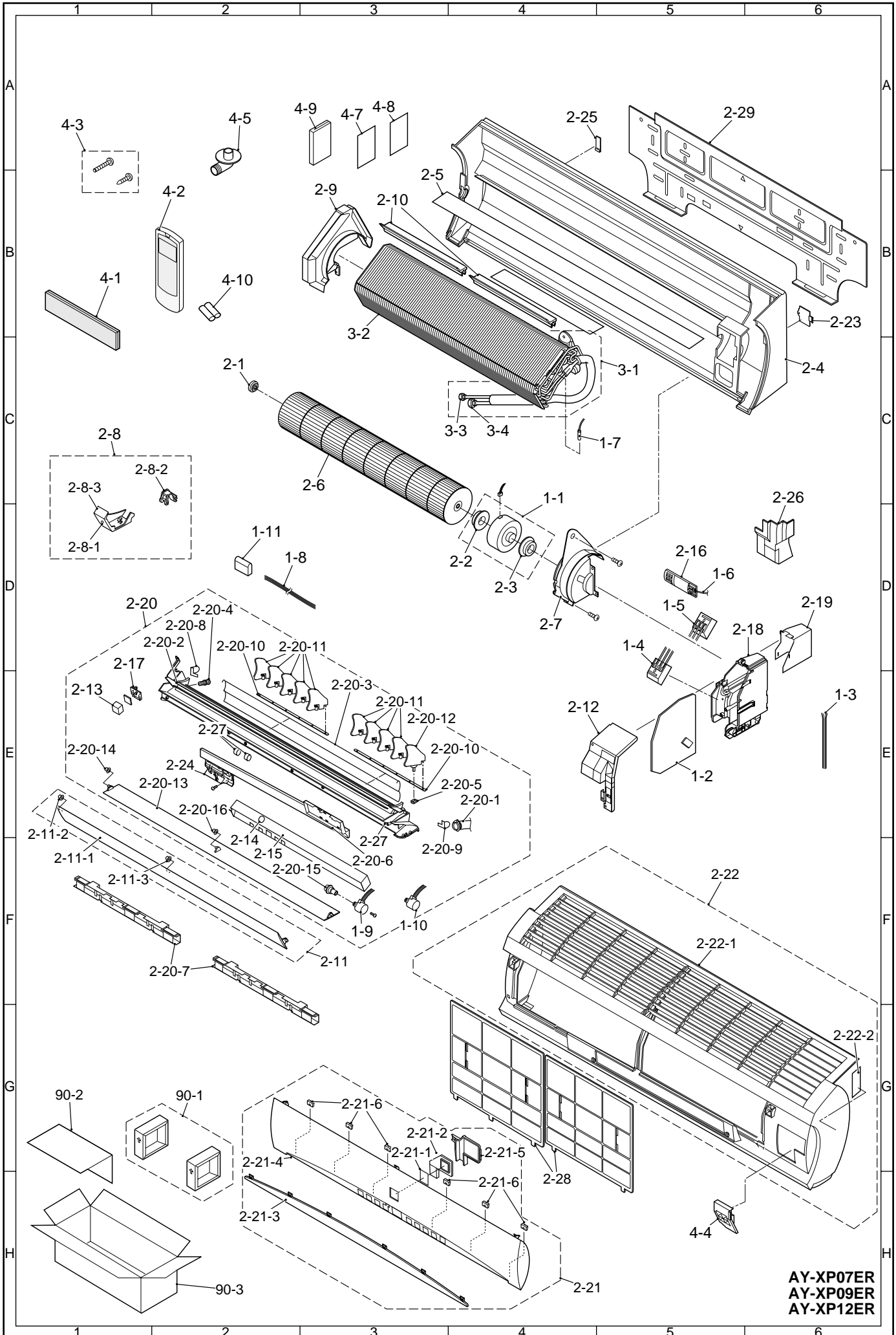

AY-XP07ER
AY-XP09ER
AY-XP12ER

REPLACEMENT PARTS LIST (AE-X07ER / AE-X09ER / AE-X12ER)

REF. NO.	PART NO.	DESCRIPTION	Q'TY	CODE
CONTROLBOX PARTS				
1- 1	CMOTLB078JBEZ	Fan moter	1	BL
1- 2	DSGY-B541JBKZ	Control board ass'y [AEX07ER]	1	CB
1- 2	DSGY-B531JBKZ	Control board ass'y [AEX09ER]	1	CB
1- 2	DSGY-B549JBKZ	Control board ass'y [AEX12ER]	1	CC
1- 2-1	QFS-GA050JBZZ	Fuse	1	AD
1- 2-2	QFS-GA051JBZZ	Fuse	1	AD
1- 2-3	QFS-GA052JBZZ	Fuse	1	AD
1- 2-4	QFS-GA058JBZZ	Fuse	1	AV
1- 2-5	QFS-GA059JBZZ	Fuse	2	AU
1- 2-6	RH-IXA694JBZZ	Ipm [AEX07ER] [AEX09ER]	1	BD
1- 2-6	RH-IXA732JBZZ	Ipm [AEX12ER]	1	BF
1- 3	QW-VZE511JBZZ	Lead wire [AEX07ER] [AEX09ER]	1	AM
1- 3	QW-VZE172JBZZ	Lead wire [AEX12ER]	1	
1- 4	RCILZA009JBZZ	Reactor	2	BA
1- 5	RTHM-A022JBE0	Thermistor	1	AN
1- 6	QTANZA001JBZZ	Terminal board	1	AQ
1- 7	QW-VZE497JBZZ	Lead wire	1	AG
1- 8	QW-VZE498JBZZ	Lead wire	1	AG
1- 9	QW-VZE499JBZZ	Lead wire	1	AF
1- 10	RFIL-A064JBE0	Ferrite core	4	AF
1- 11	RH-HXA029JBZZ	Thermistor ass'y	1	AX
CABINET AND UNIT PARTS				
2- 1	LANGKA157JBPZ	Motor angle	1	AQ
2- 2	CCAB-A367JBKZ	Top plate ass'y [AEX07ER] [AEX09ER]	1	
2- 2	CCAB-A368JBKZ	Top plate ass'y [AEX12ER]	1	
2- 3	TLABCB879JBRZ	Wiring diagram [AEX07ER] [AEX09ER]	1	AC
2- 3	TLABCB879JBRZ	Wiring diagram [AEX12ER]	1	AC
2- 4	LX-BZA261JBEZ	Special screw	4	AC
2- 5	PCOV-A881JBFA	Reactor cover [AEX07ER] [AEX09ER]	1	AL
2- 6	LANG-A504JBYZ	Reactor angle [AEX12ER]	1	AP
2- 7	CFTA-A268JBKZ	Cover	1	AN
2- 7-1	PCOV-A594JBPZ	Terminal cover	1	AE
2- 7-2	PFTA-A090JBFA	Cover	1	AL
2- 8	PRDAFA170JBEZ	Heat sink	1	AR
2- 9	FDAI-A006JBWZ	Capacitor angle assy	1	AG
2- 10	LBNDKA105JBWZ	Capacitor clamp	1	AD
2- 11	PBOX-A396JBFZ	Control box	1	AP
2- 12	PDAI-A138JBWZ	Terminal base [AEX07ER] [AEX09ER]	1	AG
2- 12	PDAI-A134JBWZ	Terminal base [AEX12ER]	1	
2- 13	PCOV-A595JBFZ	Cover	1	AE
2- 14	PSKR-A258JBPZ	Bulkhead [AEX07ER] [AEX09ER]	1	AH
2- 14	PSKR-A283JBPZ	Bulkhead [AEX12ER]	1	AS
2- 15	GCAB-A237JBTA	Front panel [AEX07ER] [AEX09ER]	1	AY
2- 15	GCAB-A220JBTA	Front panel [AEX12ER]	1	BC
2- 16	GGADPA004JBFA	Fan guard [AEX07ER] [AEX09ER]	1	AR
2- 16	GGADPA007JBFA	Fan gaurd [AEX12ER]	1	AS
2- 17	JHNDPA015JBFA	Handle	1	AD
2- 18	LHLD-A449JBF0	Thermistor holder	1	AH
2- 19	LHLD-A491JBFZ	Cord clamp	1	
2- 20	LHLD-A492JBFZ	Cord clamp base	1	
2- 21	MSPR-A026JBE0	Spring	2	AB
2- 22	MSPR-A027JBE0	Thermistor spring [AEX07ER] [AEX09ER]	1	AB
2- 23	MSPR-A036JBE0	Thermistor spring [AEX12ER]	1	AB
2- 24	MSPR-A143JBEZ	Spring [AEX12ER]	1	AD
2- 25	NFANPA110JBEZ	Propeller fan [AEX07ER] [AEX09ER]	1	AQ
2- 25	NFANPA118JBEZ	Propeller fan [AEX12ER]	1	AU
2- 26	PPLT-A370JBTZ	Side cover r [AEX07ER] [AEX09ER]	1	
2- 26	PPLT-A375JBTA	Side cover r [AEX12ER]	1	AW
2- 27	PSPF-A871JBEZ	Comp cover top [AEX07ER] [AEX09ER]	1	AF

REF. NO.	PART NO.	DESCRIPTION	Q'TY	CODE
2- 27	PSPF-A918JBEZ	Comp cover top [AEX12ER]	1	AT
2- 28	PSPF-A878JBEZ	Compressor cover [AEX07ER] [AEX09ER]	1	AT
2- 28	PSPF-A919JBEZ	Compressor cover [AEX12ER]	1	AE
2- 29	PSPF-A879JBEZ	Compressor cover b [AEX07ER] [AEX09ER]	1	AD
2- 30	CANG-A165JBKZ	Holder ass'y [AEX12ER]	1	AH
2- 31	TLAB-C511JBRA	Label	1	AC
2- 32	TLABMA356JBRA	Inverter label	1	
2- 33	TSPC-E667JBRZ	Name badgc [AEX07ER]	1	AC
2- 33	TSPC-E650JBRZ	Name badgc [AEX09ER]	1	AC
2- 33	TSPC-E679JBRZ	Name badgc [AEX12ER]	1	AC

CYCLE PARTS

3- 1	CCHS-A842JBTA	Base pan ass'y [AEX07ER] [AEX09ER]	1	
3- 1	CCHS-A884JBTA	Base pan ass'y [AEX12ER]	1	AW
3- 2	DVLV-A571JBKZ	3way valve unit [AEX07ER] [AEX09ER]	1	AU
3- 2	DVLV-A657JBKZ	3way valve unit [AEX12ER]	1	AV
3- 3	LX-NZA270JBEZ	Service nut	1	
3- 4	LX-NZA271JBEZ	Bonnet [AEX07ER] [AEX09ER]	1	
3- 4	LX-NZA307JBEZ	Bonnet [AEX12ER]	1	
3- 5	DVLV-A572JBKZ	2way valve unit	1	AQ
3- 6	LX-NZA271JBEZ	Bonnet	1	
3- 7	DVLV-A581JBKZ	Control valve ass'y [AEX07ER] [AEX09ER]	1	BG
3- 7	DVLV-A653JBKZ	Control valve ass'y [AEX12ER]	1	
3- 8	CCIL-A129JBKZ	Coil ass'y	1	AU
3- 9	PVLVXA052JBEZ	Reverse valve [AEX07ER] [AEX09ER]	1	BB
3- 9	PVLVXA061JBEZ	Reverse valve [AEX12ER]	1	BD
3- 10	PDAI-A123JBTA	Flare coupling base	1	
3- 11	PGUM-A008JBE0	Damper rubber	1	AF
3- 12	DCON-A242JBPZ	Condenser ass'y [AEX07ER] [AEX09ER]	1	BV
3- 12	DCON-A241JBPZ	Condenser ass'y [AEX12ER]	1	BV
3- 13	PCMPRA430JBEZ	Compressor	1	CC
3- 14	GLEG-A099JBE0	Compressor cushion	3	AD
3- 15	LX-NZA026JBE0	Special nut	3	

PACKING PARTS

90- 1	CPADBA773YDKZ	Top pad ass'y [AEX07ER] [AEX09ER]	1	AG
90- 1	CPADBA048JBKZ	Top pad ass'y [AEX12ER]	1	
90- 2	CPADBA774YDKZ	Bottom pad ass'y [AEX07ER] [AEX09ER]	1	AN
90- 2	CPADBA049JBKZ	Bottom pad ass'y [AEX12ER]	1	
90- 3	SPAKCB550JBEZ	Packing case [AEX07ER]	1	
90- 3	SPAKCB536JBEZ	Packing case [AEX09ER]	1	
90- 3	SPAKCB565JBEZ	Packing case [AEX12ER]	1	AU

HOW TO ORDER REPLACEMENT PARTS

To have your order filled promptly and correctly, please furnish the following information.

1. MODEL NUMBER 2. REF. NO. 3. PART NO. 4. DESCRIPTION

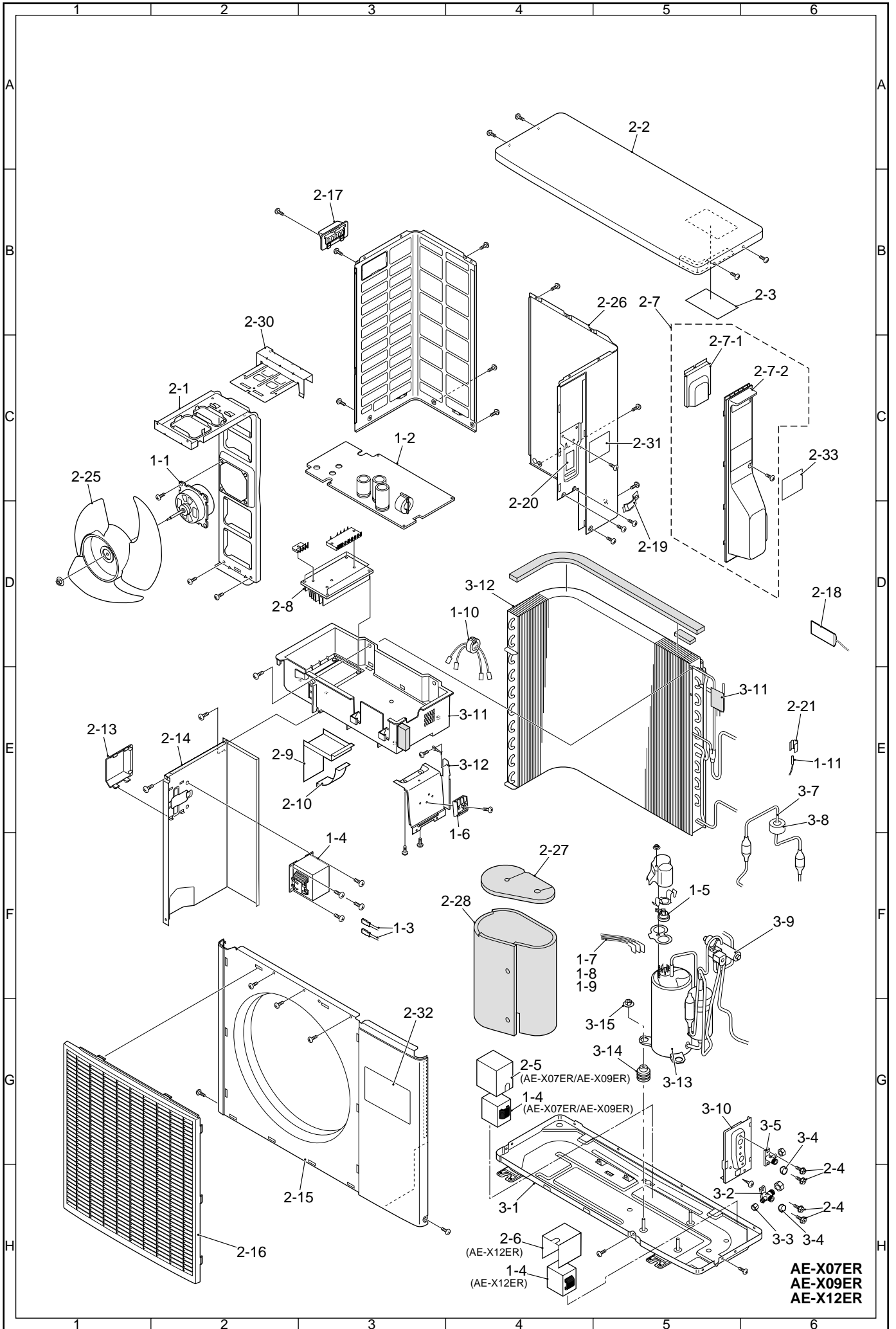

MEMO

MEMO

SHARP